

TABLE OF CONTENTS

NOTE

The plastic components of your computer may warp if exposed to excessive heat or sunlight 140° F or 60° C will do it.

PART A—CALCULATOR SIDE	PART B—WIND SIDE
Time - Speed - Distance 2	The CR "Wind" Disc 30
Fuel Consumption 4	Addition - Subtraction 32
Conversions 5	Wind Solution on the CR 33
Weight of Fuel and Oil 9	Flight Planning with Forecast Winds 37
Altitude 11	Finding Winds in Flight 41
Density Altitude 12	True Course (Track) and Ground Speed 44
True Altitude 12	True Heading and True Air Speed 48
True Air Speed 14	Off-Course Correction 51
The CR Cursor 15	Radius of Action 53
Mach Number 17	Wind Components for Takeoff and Landing 55
Temperature Rise 20	
"Old" Method - True Air Speed 21	
Pressure Pattern 23	
Slide Rule Use 25	
Time and Distance to Station 28	
	PART C—ANSWERS, DEFINITIONS AND HINTS
	Answers to Practice Problems 57
	Definitions 58
	Some Hints on the CR 60

PART A—CALCULATOR SIDE

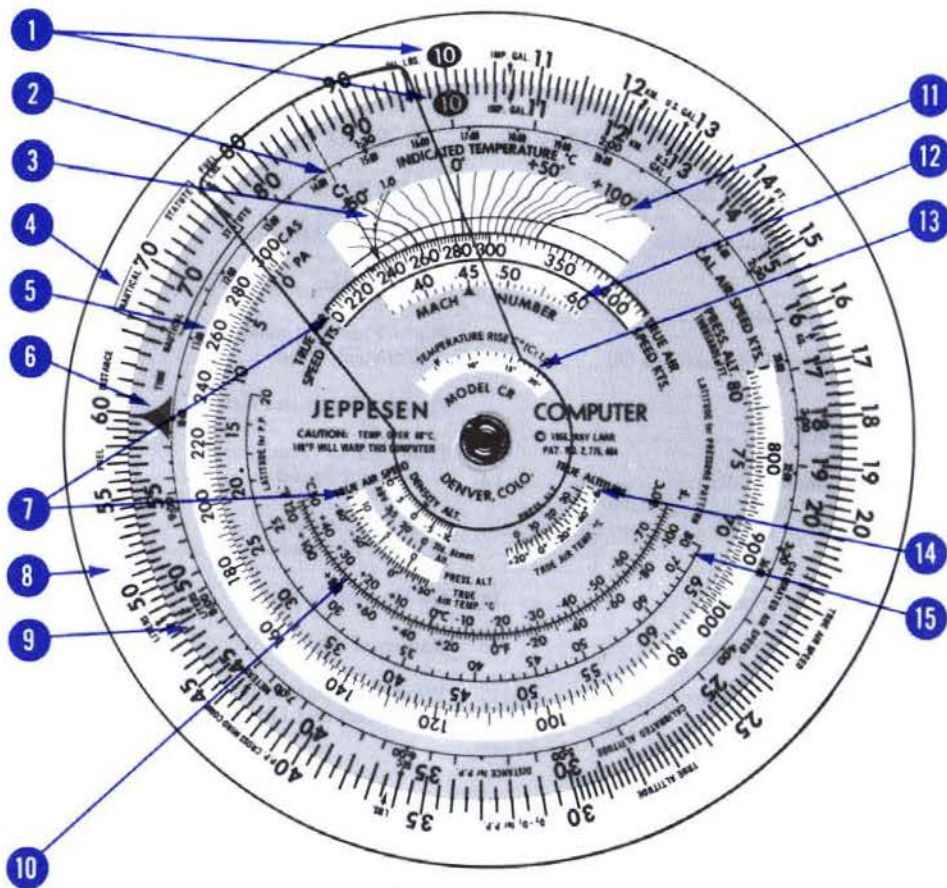

CR-2 and CR-3

- 1 Unit Index
- 2 Cursor Hairline
- 3 Recovery Coefficient 1.0
- 4 Nautical-Statute Conversion Arrows
- 5 Calibrated Air Speed Window
- 6 Time Index
- 7 True Air Speed Windows
- 8 Base Disc

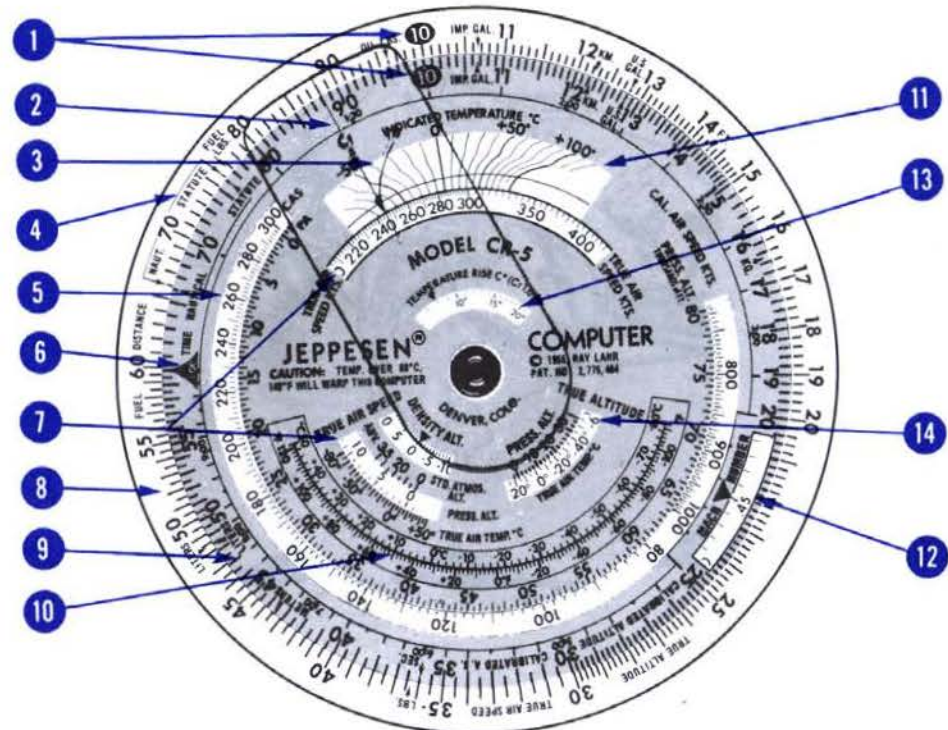

CR-5

- 9 Top Disc
- 10 Temperature Conversion Scale
- 11 Indicated Temperature Window
- 12 Mach Number Window
- 13 Temperature Rise Scale
- 14 True Altitude Window
- 15 Latitude for Pressure Pattern Scale

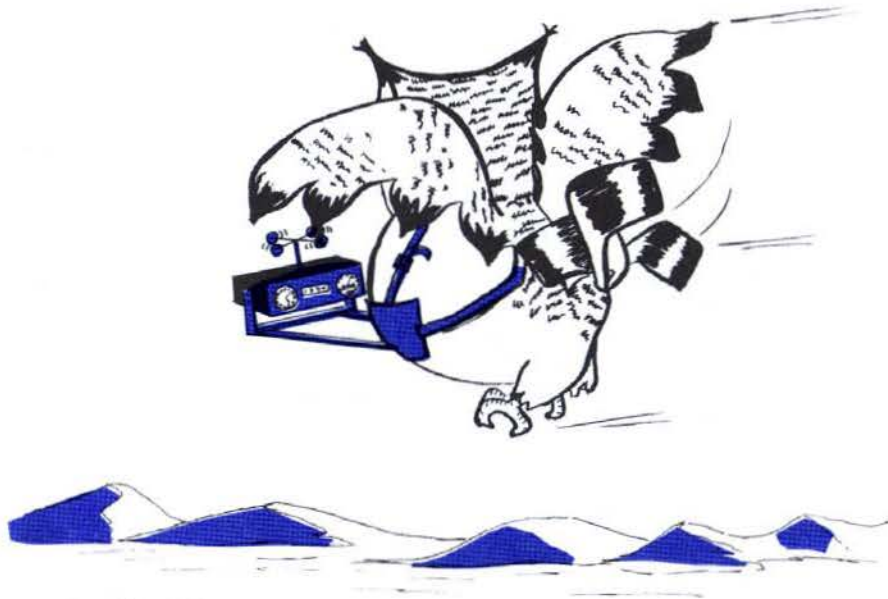

Time — Speed — Distance

“Time, speed and distance problems are solved with the CR Computer in the conventional manner . . . using the outside scales on the calculator side. For the benefit of those ‘knot so inclined,’ the CR is ‘knot knecessarily knautical’ and you can get perfectly good answers in MPH and statute. Let’s run through some quickies so’s you won’t figure ‘Ole Sharp’ is spoofing you.

“First a word about reading the scales on the CR. Each figure on the outer scales of the computer can stand for any number containing the given digits. The point marked ‘40’ can stand for .4, 4, 40, 400, etc. You must determine, from the given problem, which value is correct.”

Example

Given: Ground speed.....200 MPH
 Distance.....300 Stat. Mi.
Find: Time enroute

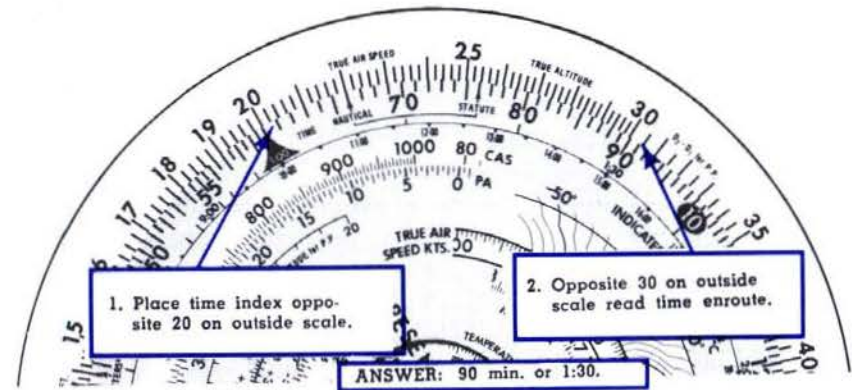

Fig. 1

Given: Distance.....210 Mi.
 Time.....50 Min.
Find: Ground speed

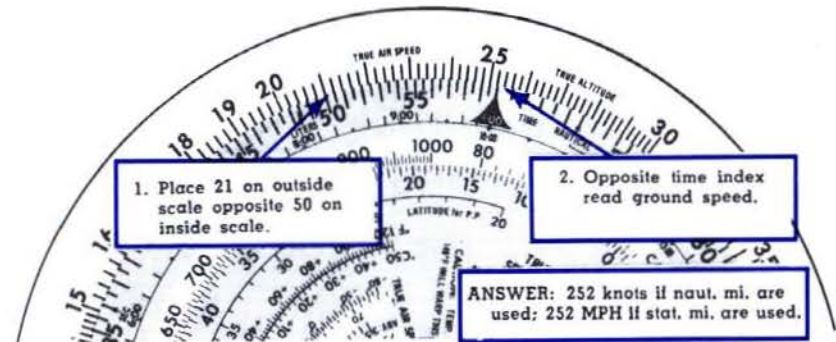



Fig. 2

To find distance if you are given ground speed and time, place time index  opposite ground speed and read distance on outside scale opposite time on inside scale.

Problems 1

(See page 57 for answers)

	Time	Ground Speed	Distance
1.	:32	480 kts.
2.	:13	42 stat. mi.
3.	340 kts.	510 naut. mi.
4.	1:40	162 MPH
5.	:36	160 naut. mi.
6.	177 MPH	660 stat. mi.

FUEL CONSUMPTION

Problems involving fuel consumption are worked in the same manner as time-speed-distance problems. Simply place gallons instead of miles on the outside scale and time on the inside scale. Gallons per hour instead of miles per hour will be read opposite the time index \blacktriangle .

If U. S. gallons (gasoline) are being used, pounds per hour may be read on the outside scale opposite the "SEC" arrow at 36 on the inside scale.

Example

An aircraft has consumed 105 U. S. gallons of gasoline in 1 hr. 30 min.

Find: Gallons per hour and pounds per hour.

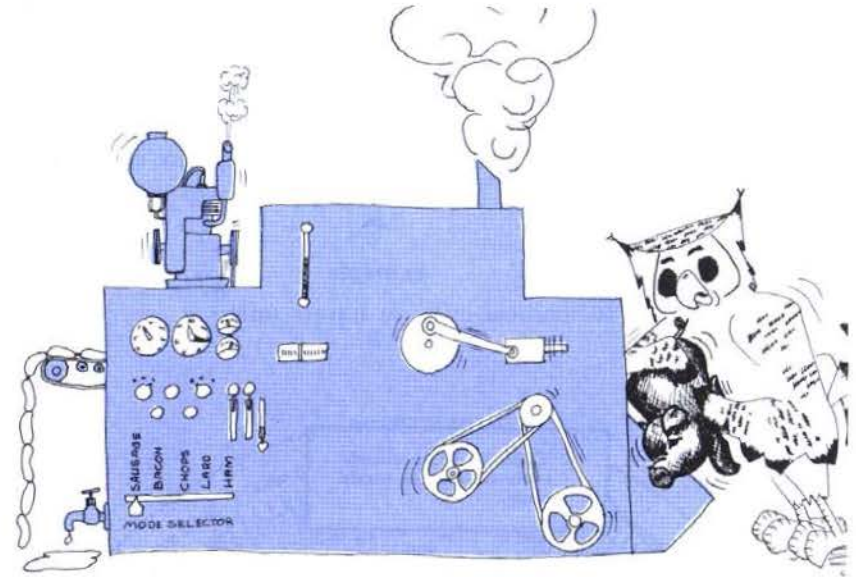
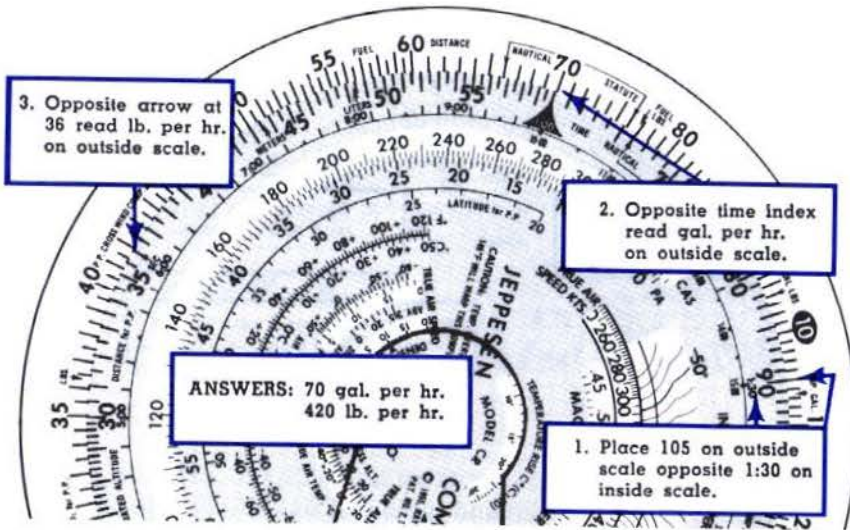

CONVERSIONS

"Things aren't always what you want them to be—
But the CR will help you change them.

- For instance, if you want to change:
- Nautical miles to statute miles or kilometers
 - U. S. gallons to imperial gallons or liters
 - Feet to meters
 - Pounds to kilograms
 - Or vice versa—

Here's how:

Note the following labeled arrows on inside and outside scales of the calculator side of the computer:

NAUTICAL miles.....	near 66 on both scales
STATUTE miles.....	near 76 on both scales
KM. (kilometers)	near 12 on both scales
IMP. GAL.....	near 11 on both scales
U. S. GAL.....	near 13 on both scales
LITERS.....	near 48 on both scales
FT.....	near 14 on outside scale
METERS.....	near 44 on inside scale
LBS.....	near 36 on outside scale
KG. (kilograms)	near 16 on inside scale

To convert between two different units of measure, simply find the arrow for the first unit of measure on one scale of the computer and place it opposite the arrow for the second unit of measure on the other scale. Read corresponding values opposite each other on the two scales.

Example

Convert 40 nautical miles to statute miles.

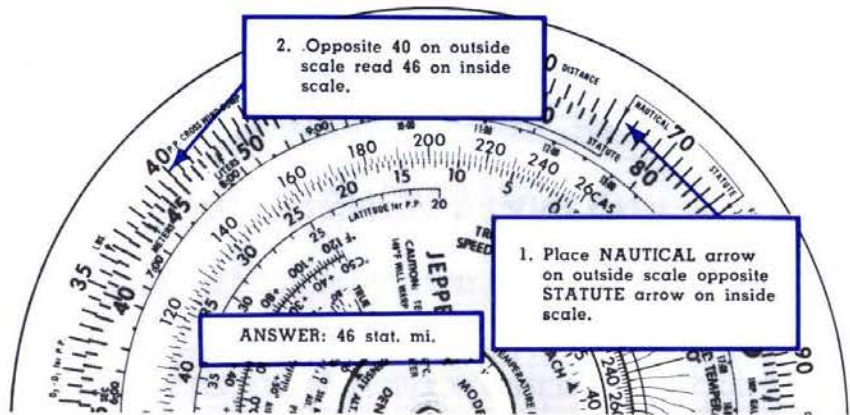

Fig. 4

This method is especially good if you have a series of quantities to convert. Only one setting is necessary for a series because every quantity on the outside scale represents nautical miles (or knots) and the corresponding values in statute miles (or MPH) are found opposite on the inside scale. 80 nautical miles = 92 statute miles, 38 statute miles = 33 nautical miles, etc. It would also have been possible to match the STATUTE arrow on the outside scale with the NAUTICAL arrow on the inside scale, reading statute miles on the outside scale and nautical miles on the inside scale.

Use the same method for all other quantity conversions. Simply match the arrows for the desired quantities.

When converting only one quantity instead of a series of quantities, the following method may be preferred:

Example

Convert 40 nautical miles to statute miles.



Fig. 5

This method may be used for converting among nautical miles, statute miles, and kilometers; and among imperial gallons, U.S. gallons, and liters. It may not be used to convert between feet and meters or pounds and kilograms because all arrows for the latter conversions are on opposite scales.

Celsius - Fahrenheit

A temperature conversion scale is located on the calculator side of the CR. Read temperature conversions directly from this scale.

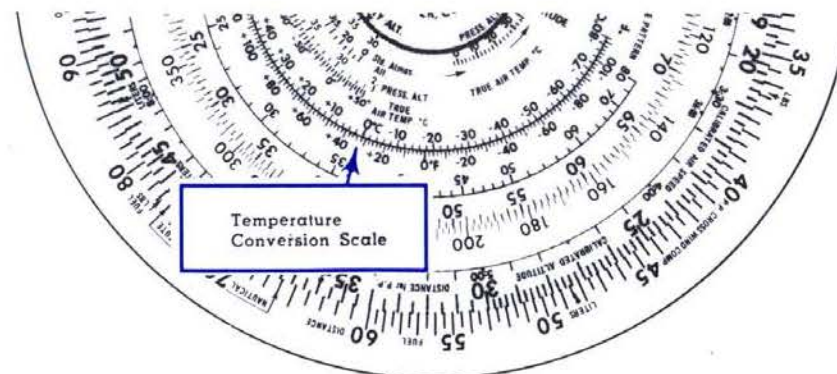

Fig. 6

Problems 2

1. 100 nautical miles = statute miles
2. 196 statute miles = nautical miles
3. 90 statute miles = Kilometers
4. 250 kilometers = nautical miles
5. 53 U.S. gallons = imperial gallons
6. 80 imperial gallons = U.S. gallons
7. 198 imperial gallons = liters
8. 140 liters = U.S. gallons
9. 117 pounds = kilograms
10. 90 kilograms = pounds
11. -20°C = $^{\circ}\text{F}$
12. 50°F = $^{\circ}\text{C}$

To help in checking "reasonableness" of your answer, NOTE:

- 1 km. = approx. .5 naut. mi.
- 4 liters = approx. 1 U.S. gal.
- 1 kg. = approx. 2 lbs.
- 1 imp. gal. = approx. 1.2 U.S. gal.

Meters to Feet

Are you perplexed because the constant pressure charts issued by the National Weather Service express altitudes in meters instead of feet? That is no trouble at all. The CR makes the conversion by lining up the meters arrow near 44 on the inner scale and the feet arrow near 14 on the outer scale. This sets up the correct proportion of feet and meters. Then, all values on the inner scale represent meters and those on the outer scale represent corresponding values in feet.

Example

Change 2,500 meters to feet.

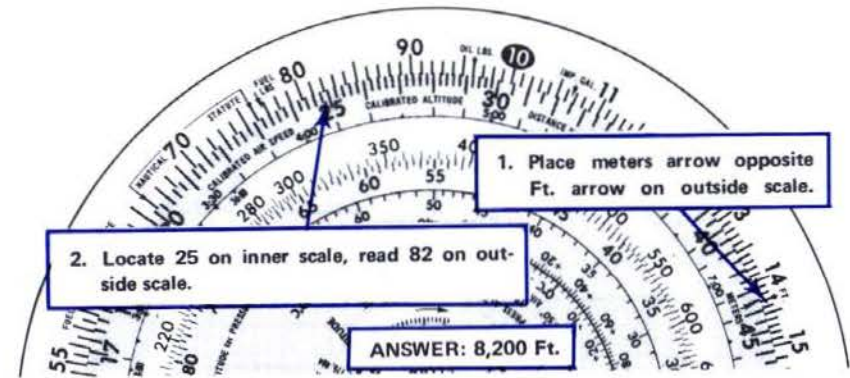

Fig. 7

To check the "reasonableness" of your answer, remember that 1 meter equals approximately 3.3 feet.

Problems 3

1. 230 feet = meters
2. 3,500 meters = feet
3. 82 feet = meters
4. 5,500 meters = feet

WEIGHT OF FUEL AND OIL

Want to know how much your fuel and oil weigh? Use the following labeled arrows:

- FUEL LBSnear 77 on outside scale
- OIL LBSat 96 on outside scale

Example

Find weight of 18 U. S. gal. of gasoline.

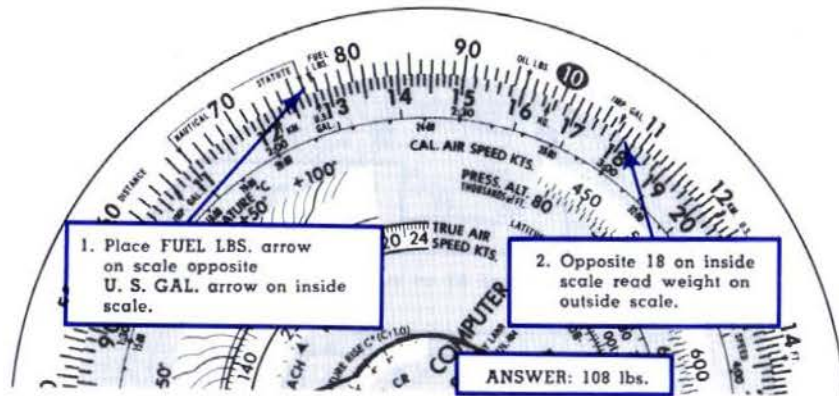

To find the weight of imperial gallons, match the FUEL LBS. arrow with the IMP. GAL. arrow on the inside scale and proceed as above.

To find the weight of oil, use the OIL LBS. arrow at 96 on the outside scale and match with the proper GAL. arrow on the inside scale, using the same method as in finding fuel weight.

Problems 4

Find the weight of:

- | | |
|---------------------------|----------------------|
| 1. 35 U. S. gal. gasoline | 3. 50 imp. gal. oil |
| 2. 500 imp. gal. gasoline | 4. 18 U. S. gal. oil |

Minutes to Seconds

At 36 on the inside scale is an arrow marked SEC. To convert minutes to seconds, place the time index \blacktriangle opposite the number of minutes and read seconds opposite SEC arrow.

Example

Find number of seconds in $13\frac{1}{2}$ minutes. Place time index \blacktriangle opposite $13\frac{1}{2}$. Opposite SEC arrow (near 36 on inside scale) read 81.

Answer: $13\frac{1}{2}$ minutes = 810 seconds.



ALTITUDE

Altitude comes in assorted varieties. Ever wonder how high is "up?" No need for confusion if you remember the following points:

Indicated Altitude is the altitude reading on the altimeter, assuming it is correctly set. It shows the approximate height of the aircraft above mean sea level (MSL).

Calibrated Altitude is the indicated altitude corrected for instrument, position, and installation errors.

True Altitude is computed by correcting calibrated altitude for nonstandard atmospheric conditions. It is the actual height of the aircraft above sea level.

Pressure Altitude is the reading on the altimeter when it is set to 29.92. Pressure altitude is an important factor for determining aircraft performance.

Density Altitude is pressure altitude corrected for nonstandard temperature. Aircraft performance is affected by density altitude.

DENSITY ALTITUDE

Near the center of the computer at the bottom left is the density altitude window.

Example

Given: Pressure altitude 3000'
 True air temperature . . . 25°C
Find: Density altitude

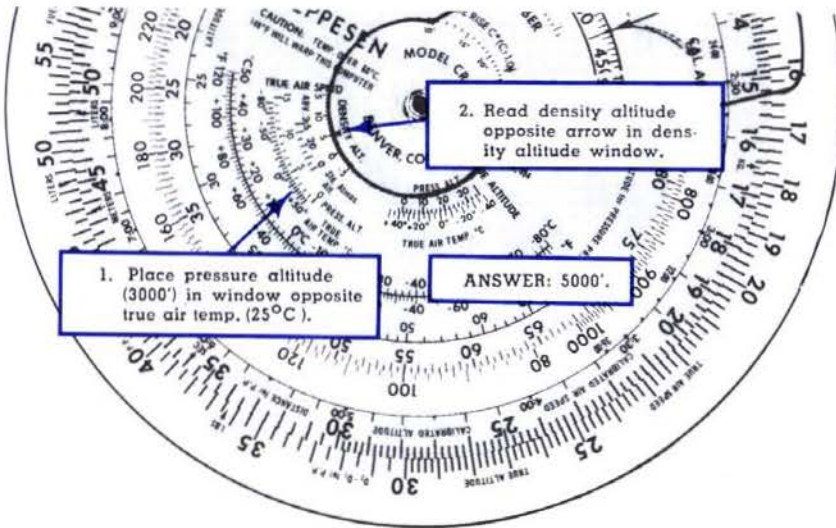

Fig. 9

Problems 5

Find density altitude for the following conditions:

	Pressure Altitude	True Air Temperature
1.	1500'	35°C
2.	0'	40°C
3.	8000'	-10°C

TRUE ALTITUDE

To find the approximate true altitude, use calibrated altitude (or indicated if calibrated is not available) and true air temperature. Greater accuracy can be obtained if you also know the altitude of the ground station giving your altimeter setting.

Example

Given: Pressure altitude.....10,000'
 Calibrated altitude..... 9,000'
 True air temperature.....-20°C
 Ground station altitude... 5,000'
Find: True altitude

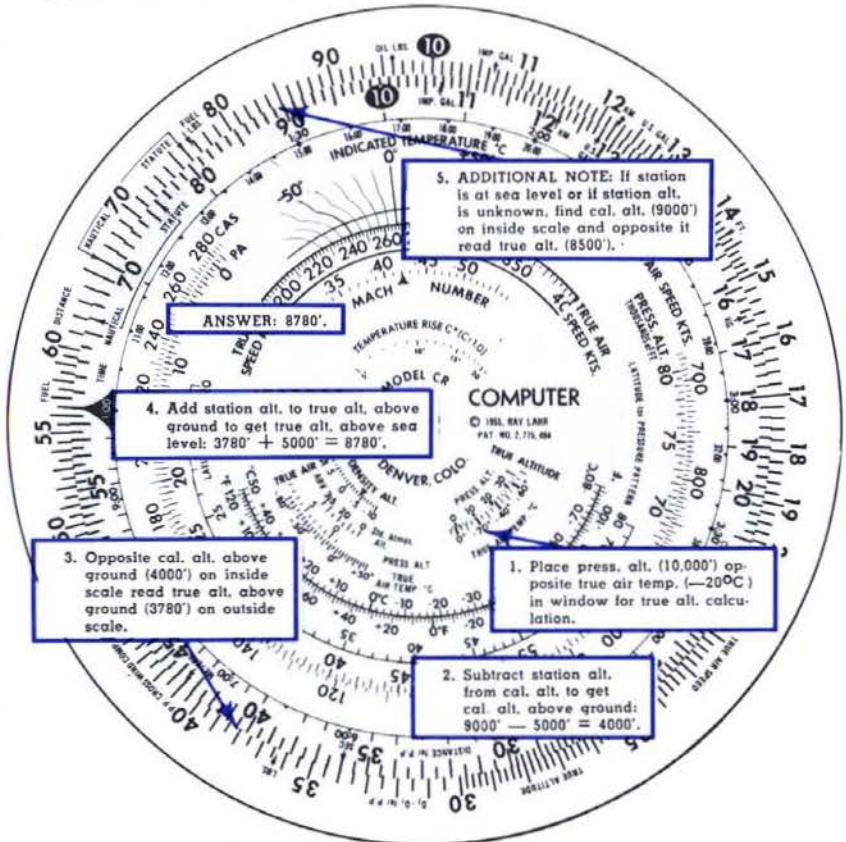

Fig. 10

Problems 6

Find true altitude:

	Pressure Altitude	True Air Temp.	Calibrated Altitude	Station Altitude
1.	10,000'	25°C	11,400'	4,200'
2.	5,000'	0°C	6,000'	Sea Level
3.	7,000'	10°C	7,400'	1900'
4.	20,000'	-15°C	21,000'	Unknown



TRUE AIR SPEED

In the old days pilots listened to the wind in the wires and were happy to be flying at *any* speed. Today we have accurate air speed indicators. It's a mighty fine gadget, but its reading is affected by various items such as temperature, pressure, compressibility, and accidental misreading by the pilot who may be thinking of something else. The CR computer is effective in correcting for all errors except the last.

A fast-flying aircraft pushes through the atmosphere so rapidly that the air can't get out of the way fast enough. Hence the air is compressed in front of the aircraft and is heated by compression. As a result, an outside air temperature bulb 'feels' a higher air temperature than really exists in the surrounding non-compressed air. Also, the rush of air over the outside air temperature bulb creates friction, causing further heating and a still higher (false) reading. The amount of this higher reading of the thermometer is called 'temperature rise' and must be considered when computing accurate true air speed.

An automatic compensation for compressibility, temperature rise and air friction is built into the CR Computer so that no reference to graphs and tables and no separate figuring is necessary for correct true air speed solutions.* For this reason the CR is especially adapted to the problems of modern aircraft.

*Some aircraft manufacturers provide air speed conversion tables that already include corrections for the temperature rise effect of compressibility in addition to correction for position and instrument error. The use of such tables or other air speed data already corrected for temperature rise will result in a double correction with erroneous results from the CR computer.

While either knots or MPH can be used with the CR Modern True Air Speed Solution, more accurate true air speed answers will result from using knots when dealing with speeds over 200. The following quantities are necessary for true air speed determination: calibrated air speed (indicated air speed corrected for instrument and position errors), pressure altitude (altitude read from altimeter when instrument is set at 29.92), and indicated outside air temperature in degrees Celsius. If calibrated air speed and pressure altitude are not available in a problem, indicated air speed and altitude may be used instead. Remember, however, the CR contains no crystal ball and gives answers only as accurate as the data fed into it.

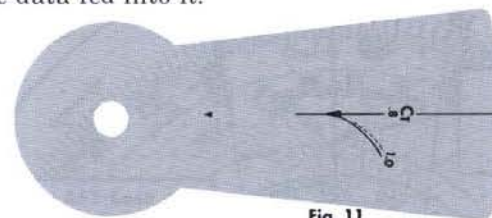

Fig. 11

THE CR CURSOR

True air speed calculations are affected by a temperature recovery coefficient, C_T , which varies with installation and design of the temperature probe on the individual airplane. Recovery coefficients vary from .6 to 1.0. Once a recovery coefficient is determined for a particular airplane, the coefficient will not vary greatly with speed or altitude.

The cursor on the CR is marked with a straight hairline and a curved line to the right of it (see Fig. 11), with recovery coefficients plotted for C_T values of .8 and 1.0.

The recovery coefficient of $C_T = .8$ is the straight line. On the CR-2 and CR-3 there are two lines plotted for the C_T value of 1.0. The solid line is for the standard stratosphere temperature of -55°C (35,000'), and a dashed line is for the standard sea level temperature of $+15^\circ\text{C}$. When flying between sea level and 35,000 feet, it is necessary to interpolate between the two lines. For instance, at an altitude of 17,500 feet with a C_T of 1.0, note that 17,500 feet is one-half the way between sea level and 35,000 feet. Hence, one-half of the space between the sea level curve and stratosphere curve of $C_T = 1.0$ must be used for the correct C_T curve.

In all problems in this book, it is assumed that the recovery coefficient is the more common 1.0, unless otherwise stated.

Example

Given: Calibrated air speed.....400 kts.
 Pressure altitude.....15,000'
 Indicated air temperature...30°C

Find: True air speed

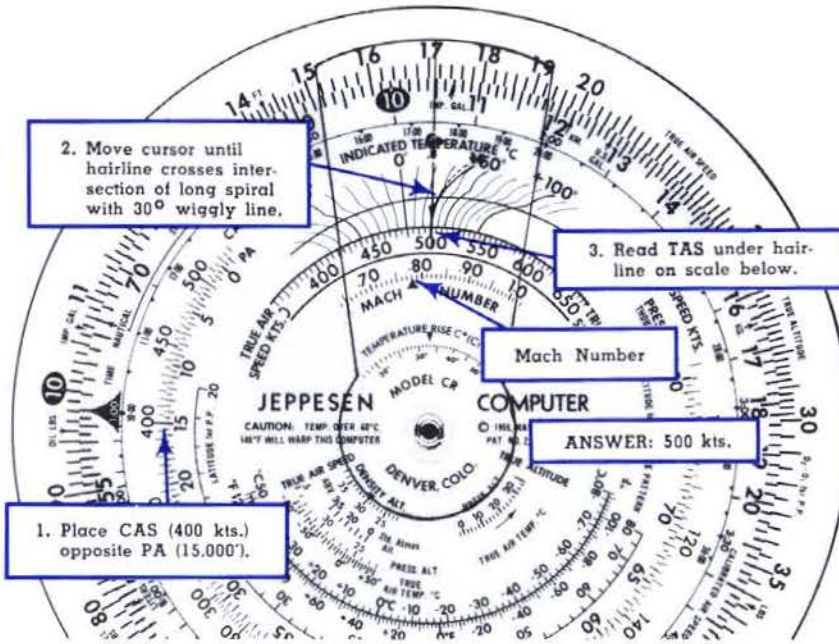

Fig. 12

Problems 7

Find true air speed:

	Calibrated Air Speed	Pressure Altitude	Indicated Air Temperature
1.	180 MPH	5,000'	+ 5°C
2.	276 kts.	16,000'	-15°C
3.	355 kts.	20,000'	5°C

MACH NUMBER

In figure 12, read Mach Number, .78, at the pointer on the scale directly beneath the True Air Speed scale. This value indicates that the aircraft is flying at .78 times the speed of sound. Since Mach Number is dependent upon the speed of sound, which varies only with temperature, the same Mach Number represents different true air speeds at different temperatures.

True Air Speed From Mach Number and Temperature

In aircraft having a Mach indicator it is possible to get true air speed from Mach Number and temperature.

Example

Given: Mach Number 1.16
 Indicated air temperature +10°C

Find: True air speed

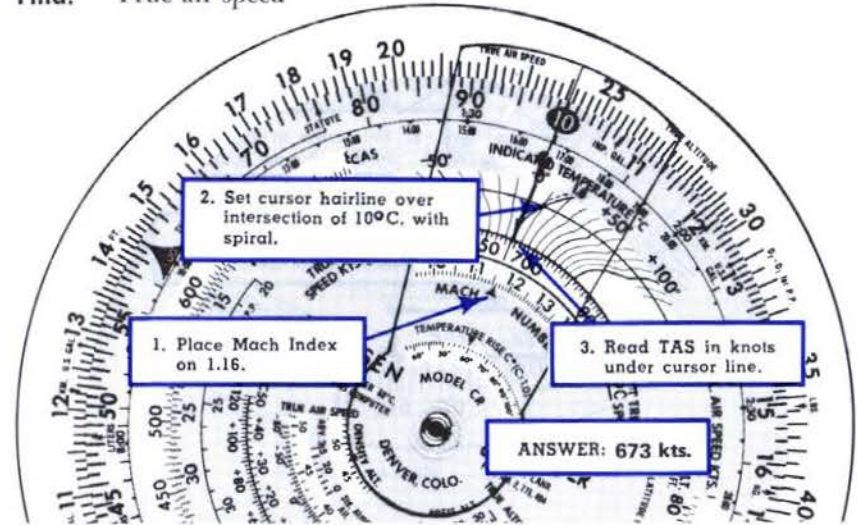

Fig. 13

If outside air temperature is not available it is possible to find true air speed by using reported or estimated air temperature (in which case the result is only as accurate as the estimate).

Use of Double-ended Mach Index Arrow

To find double-ended Mach Index arrow, set the 10 index (outer edge of top disc) near the 60 on the base disc. (This setting is made simply as a means of finding the double-ended arrow quickly.) In the small window below and left of computer center you will see a two-directional arrow labeled Mach Index.

The double-ended Mach Index arrow relates a "standard atmosphere" altitude with the standard temperature for that altitude. The temperature of the "standard atmosphere" may be of assistance in estimating outside air temperature.

Example

Given: Pressure altitude 28,000'

Find: Estimated free air temperature

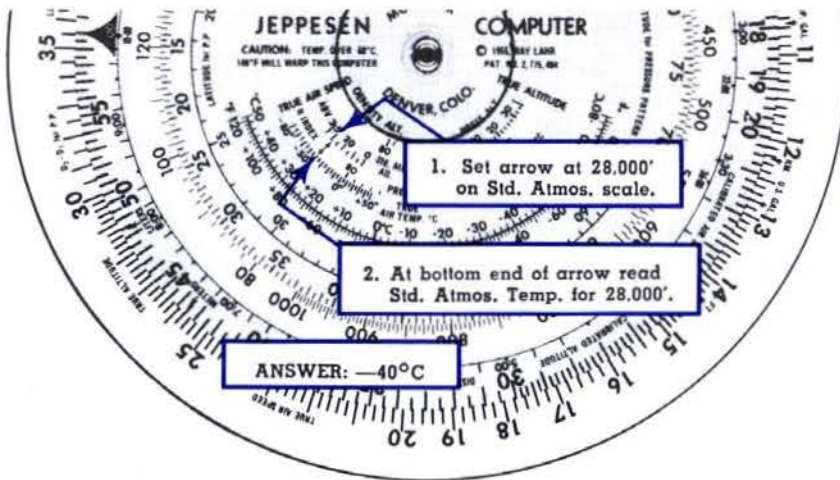

Fig. 14

NOTE: The -40°C obtained in the above example is estimated *true* air temperature. The methods of finding true air speed outlined in Figs. 12 and 13 make use of *indicated* air temperature. See the following section for the best method of finding true air speed when *true* air temperature is available.

True Air Speed From True Air Temperature

If your airplane is equipped with a Mach indicator, and you know the true air temperature, simply read the indicated Mach Number, and proceed as shown below in Fig. 15.

However, if your airplane is equipped with a conventional air speed indicator instead, it then becomes necessary to first determine the Mach Number. This is done as follows:

Example

Given: Calibrated Air Speed 280 kts.
 Pressure Altitude 14,500'
 True Air Temperature -15°C

Find: Mach Number
 True Air Speed

First place calibrated air speed opposite pressure altitude (as was done in Fig. 12, Page 16) and find the Mach Number, .55 in the Mach Number window.

Now you have the necessary data (true air temp. -15°C and Mach .55) to proceed as shown in Fig. 15 below.

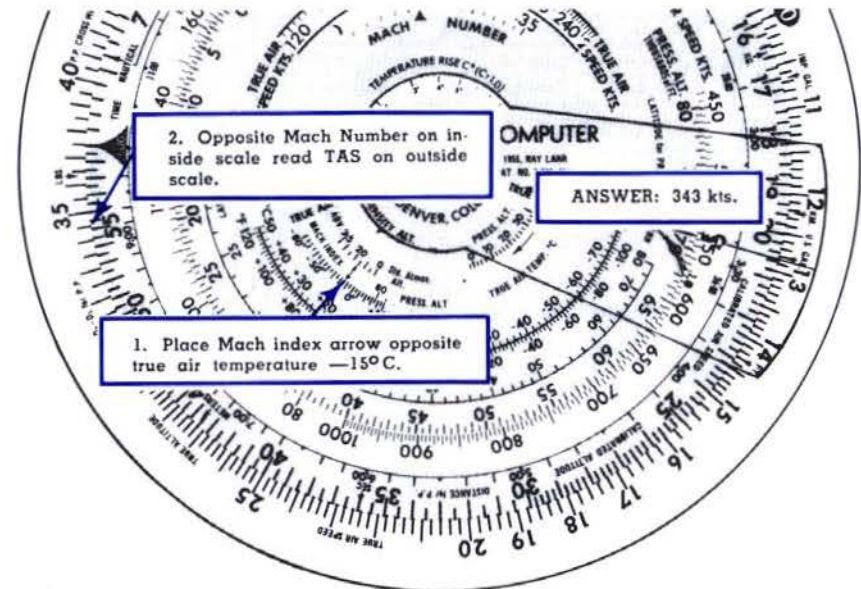
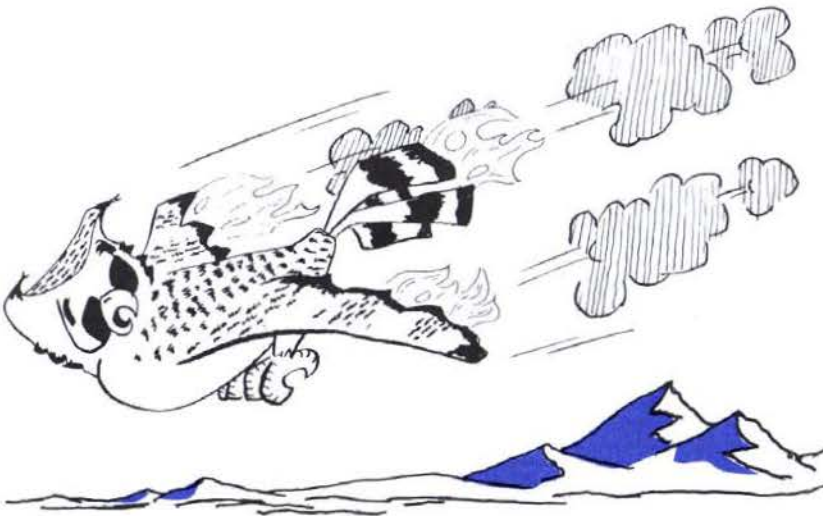

Fig. 15

TEMPERATURE RISE

In flight, particularly at high airspeeds, an outside air temperature thermometer will read higher than the actual free air temperature because of friction and compression of air at the temperature probe. The CR Computer is designed to correct for temperature rise using the two most popular recovery coefficients.

Today's jets are equipped with temperature probes which have recovery coefficients of 1.0, while many older ones have a coefficient of .8. The scale near the center of the computer entitled "TEMPERATURE RISE C° (C_T 1.0)" has been designed to reflect the temperature rise indicated by a C_T 1.0 temperature probe.



If the temperature rise is desired for a temperature probe with a C_T of .8, the C_T .8 cursor line is used and the value found on the "TEMPERATURE RISE C° (C_T 1.0)" scale is multiplied by .8.

Example

Given: Calibrated air speed 276 kts.
 Pressure altitude 10,000'
 Indicated air temperature 0°C
 Recovery coefficient 1.0

Find: True air temperature

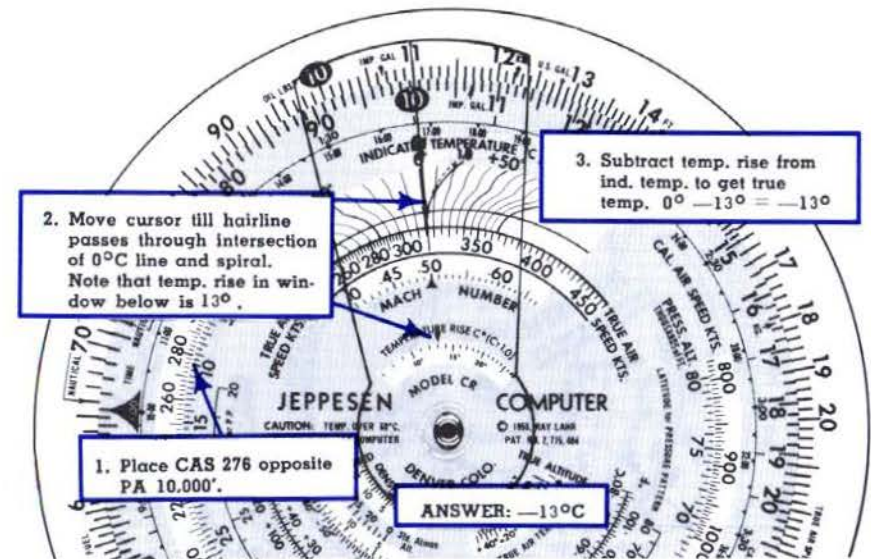

Fig. 16

Problems 8

Find temperature rise and true air temperature: (C_T 1.0)

	Calibrated Air Speed	Pressure Altitude	Indicated Air Temperature
1.	190 kts.	5,000'	0°C
2.	350 kts.	17,000'	-10°C

"OLD" METHOD — TRUE AIR SPEED

An older method for finding true air speed consists of matching pressure altitude and true air temperature in the small true air speed window near the lower left center of the computer and reading true air speed on the outside scale opposite calibrated air speed on the inside scale. This method does not correct for temperature rise and compressibility and is not suited to problems involving high-speed aircraft.

Example

Given: Calibrated Air Speed 166 kts.
 Pressure Altitude 5000'
 True Air Temperature 10°C

Find: True Air Speed

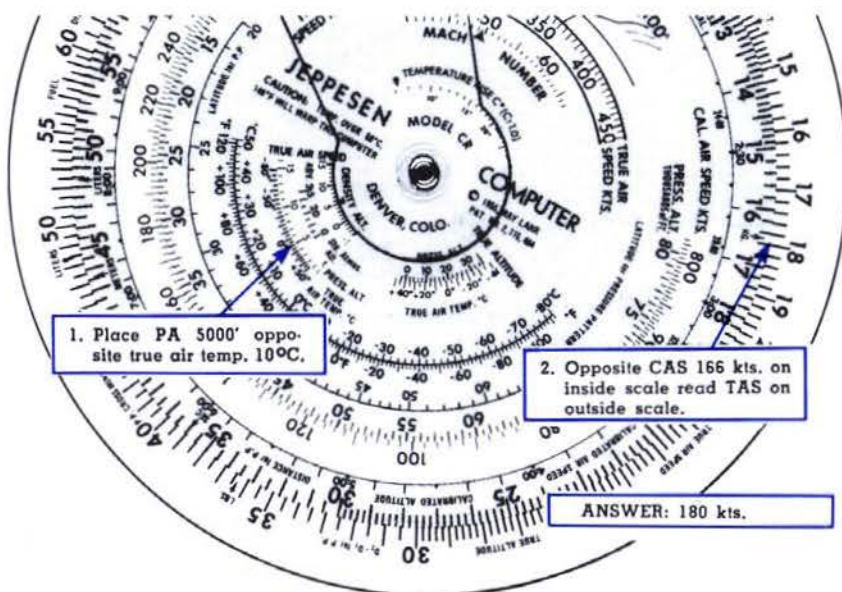

Fig. 17

When taking FAA written examinations, the "old" method for true air speed questions is recommended. These exams seldom require computations involving temperature rise.

Problems 9

Find true air speed using the method outlined above:

	Pressure Altitude	True Air Temperature	Calibrated Air Speed
1.	7,000'	0°C	210 kts.
2.	10,000'	-20°C	188 MPH

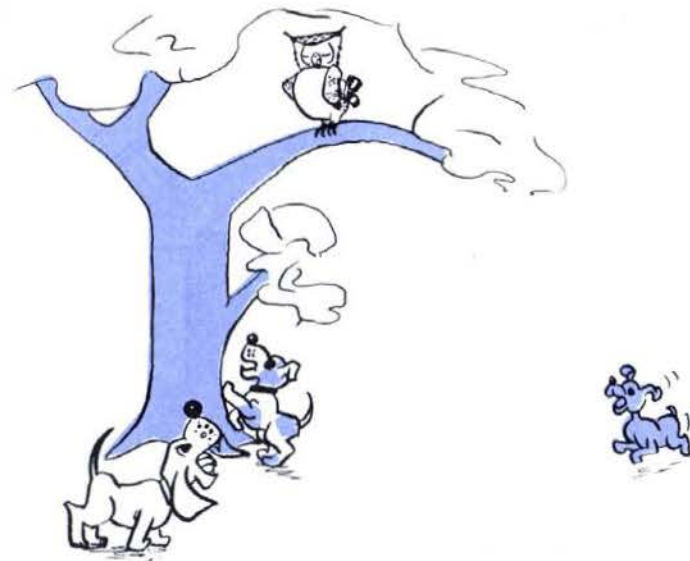

PRESSURE PATTERN

"Sometimes the longest way 'round is the shortest way home."

See the Jeppesen CR Computer Manual/Workbook or a good navigation text for further explanation of pressure pattern navigation. However, if you already know something about it, here's how to find cross-wind component with the CR Computer.

$D = \text{radio altimeter reading} - \text{pressure altimeter reading}$

D_1 and D_2 designate first and second readings respectively, taken with an intervening time interval.

In the Northern Hemisphere if $D_2 - D_1$ is positive, wind is from the right. If $D_2 - D_1$ is negative, wind is from the left. In the Southern Hemisphere this rule is reversed.

Example

Given: $D_1 = 480'$
 $D_2 = 300'$
 Distance traveled between readings.....150 naut. mi.
 Mid-latitude.....41°N

Find: Cross wind component

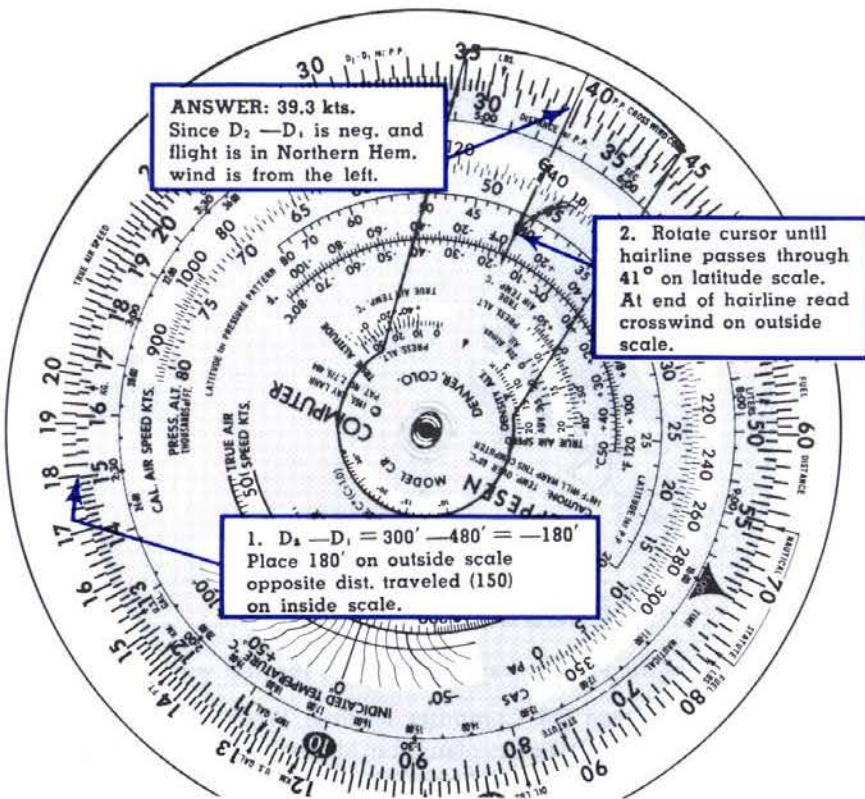
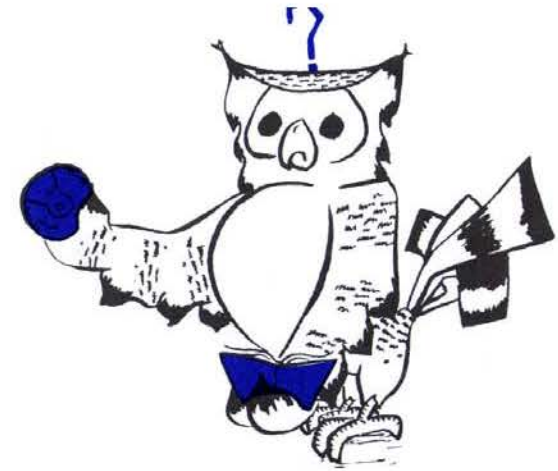

Fig. 18

Problems 10

Find crosswind component:

	D_1	D_2	Dist. Flown Between Readings	Average Latitude
1.	20'	100'	130 naut. mi.	$35^\circ N$
2.	210'	380'	152 naut. mi.	$44^\circ N$
3.	605'	520'	125 naut. mi.	$54^\circ S$



SLIDE RULE USE

“The $4\frac{1}{4}$ " diameter CR-2 log scales are approximately equivalent to those of a 12" 'straight rule'. The 6" diameter CR-3 scales are equivalent to those of a 17" straight slide rule and the $3\frac{3}{4}$ " CR-5 scales equal a 10" rule.”

Multiplication and division are performed on the calculator side of the CR in the same manner as on a straight slide rule. Be careful not to confuse the time index \blacktriangle , which stands for 60, with the unit index in these problems.

Example: 28×15

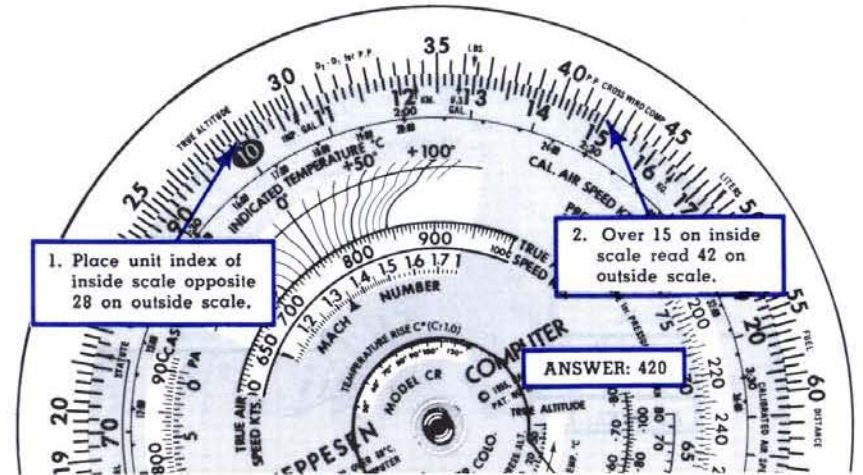

Fig. 19

Example: $182 \div 14$

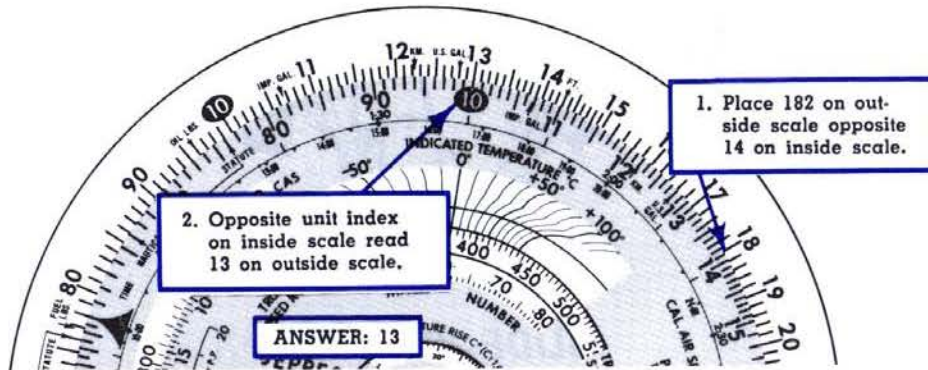

Fig. 20

Example: $\frac{25 \times 12}{19}$

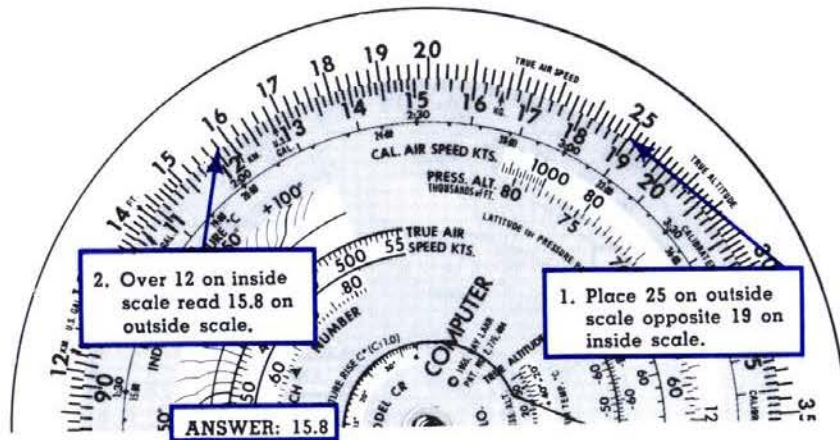

Fig. 21

Successive multiplication and division may be done on the CR by using the hairline of the cursor.

NOTE: It is necessary to estimate answer by replacing numbers in problem by numbers that are close in value but easier to multiply and divide. For instance, in problem above, the figures are similar to $\frac{25 \times 10}{20}$, which equals 12.5. Hence the answer above must be 15.8, not 158 or 1.58.

The problem might be carried a step farther:

Example: $\frac{25 \times 12}{19 \times 69}$

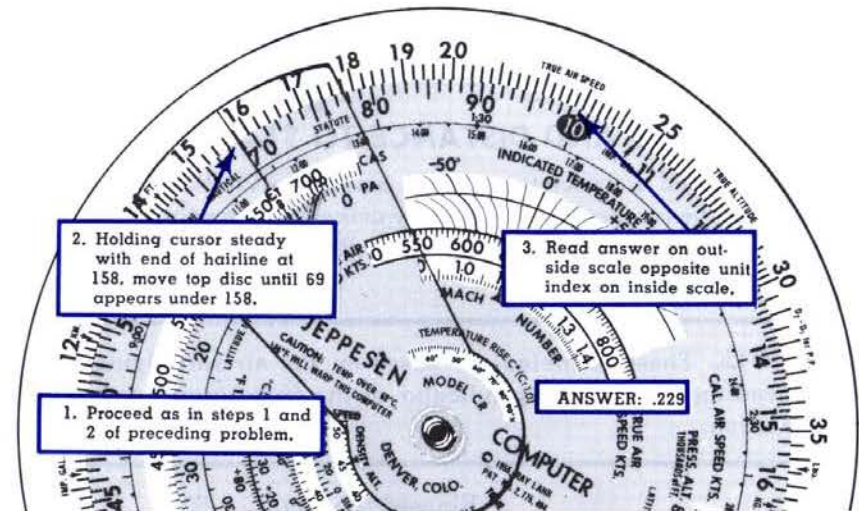
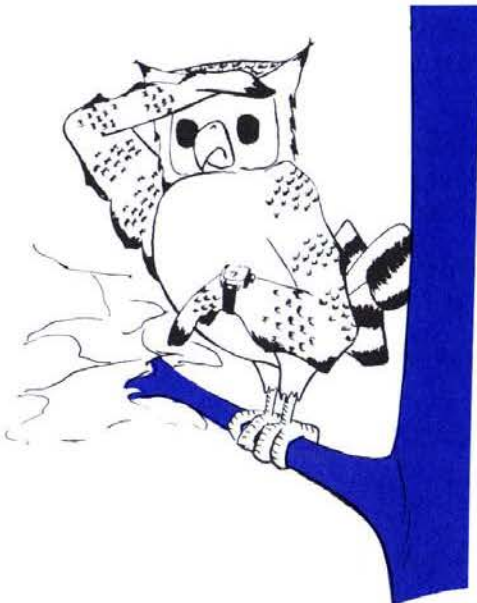

Fig. 22

Problems 11

1. $12.6 \times 31 =$
2. $267 \div 156 =$
3. $\frac{32 \times 18}{25 \times 12.8} =$



TIME AND DISTANCE TO STATION

Time and distance to a station using two VOR or ADF bearings may be computed on the CR by using the preceding multiplication and division process (see Slide Rule Use, Pg. 25) with the following formulas:

NOTE: These formulas are based on the aircraft flying a heading which is perpendicular to the *first* bearing to the station.

$$\text{Time to Station} = \frac{\text{Elapsed time (min.)} \times 60}{\text{Degrees of change}}$$

$$\text{Distance to Station} = \frac{\text{Elapsed time (min.)} \times \text{G.S.}}{\text{Degrees of change}}$$

Example

Given: First bearing taken at 10:15 = 90°
 Second bearing taken at 10:18 = 99°
 A constant heading is maintained between bearings

Find: Time to station

Solution:

$$\text{Time to Station} = \frac{\text{Elapsed time (min.)} \times 60}{\text{Degrees of change}} = \frac{3 \times 60}{9}$$

On calculator side, set 3 on outside scale opposite 9 on inside scale. Opposite 60 (1:00) on inside scale read answer on outside scale:

Answer: 20 minutes

Problems 12

Given: 1st bearing 280° at 8:26
 2nd bearing 269° at 8:31
 G.S. = 120 mph

Find: 1. Time to station
 2. Distance to station

CONVERTING CLIMB PER MILE TO CLIMB PER MINUTE

Some IFR departure procedures require a minimum climb rate to assure proper obstruction clearance. This climb requirement, stated in feet per mile, can easily be converted to feet per minute on a CR.

Given: 120 Knot ground speed
 300 feet per nautical mile climb required

Find: Feet per minute climb rate required

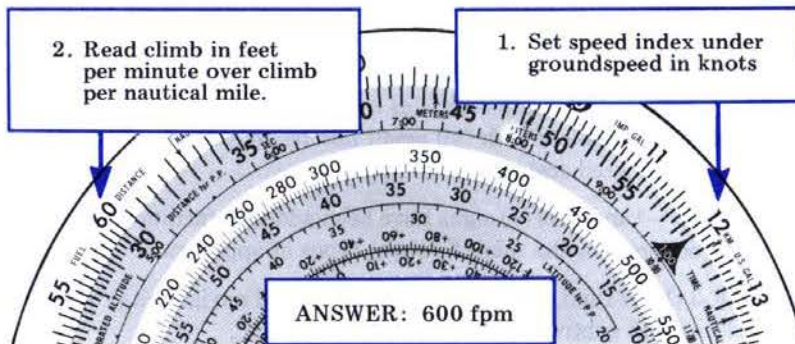

Part B WIND SIDE

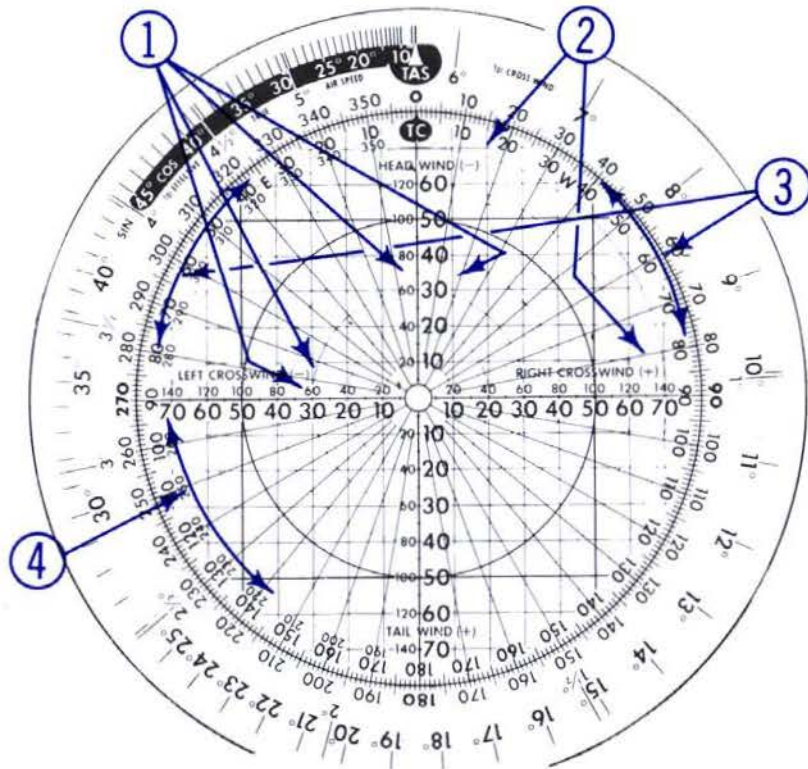

THE CR "WIND" DISC

1. The "2-value" scale system provides you with an easy way to make accurate calculations, even when solving problems where the wind velocity exceeds 100 knots. The basic solutions are the same with either scale. . . the only difference is that you have a choice of the scale best suited to the velocities involved in a particular problem. Work each problem with "all small numbered scales" or "all in the large numbered scales."
2. Minus (—) and plus (+) signs have been added to facilitate required "corrections" for the more frequent types of application.
3. (CR-3 Only) Dual, 0° thru 180° scales for grid navigation problems, adding and subtracting and other uses.

4. (CR-3 Only) Clockwise 0° thru 360° scale for ADF relative bearing solutions and other uses.

(3 and 4 above are more fully explained in the new, large Jeppesen CR Computer Manual/Workbook, the BW-2.)

CR-5 COMPUTER

The CR-5 is very similar to the CR-2 Computer except a few less frequently used functions were eliminated in order to maintain readability with the reduced size, 3¾" dia. The modern true air speed solution was slightly altered and the wind scale also somewhat reduced to permit this very small computer to function.

Your Jeppesen CR Computer is the finest instrument of its kind available at any price...we sincerely hope that it will become your favorite "cockpit companion."

ADDITION-SUBTRACTION

“Even if you’re a genius at mental arithmetic you’ll find it relaxin’ to let the CR Computer take the work out of addition, subtraction, multiplication and division.”

“Addition and subtraction of numbers up to 360 can be accomplished on the wind side of the CR-3 Computer, using the outside green scale of the top disc and the black scale curving either side of the TC index on the middle disc. On the CR-3 Computer the latter scale can be read as high as 180° to the left and 360° to the right. The smaller, CR Computers carry the scale only as high as 30 on each side of the TC index.

Example

Add 84 and 29.

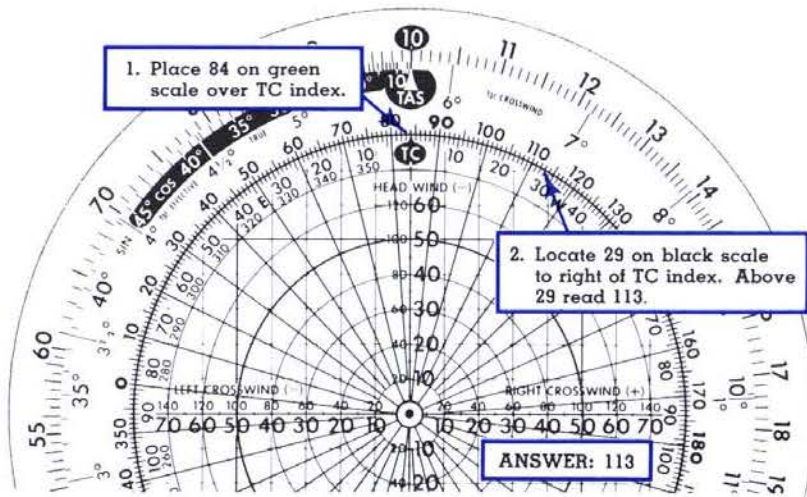
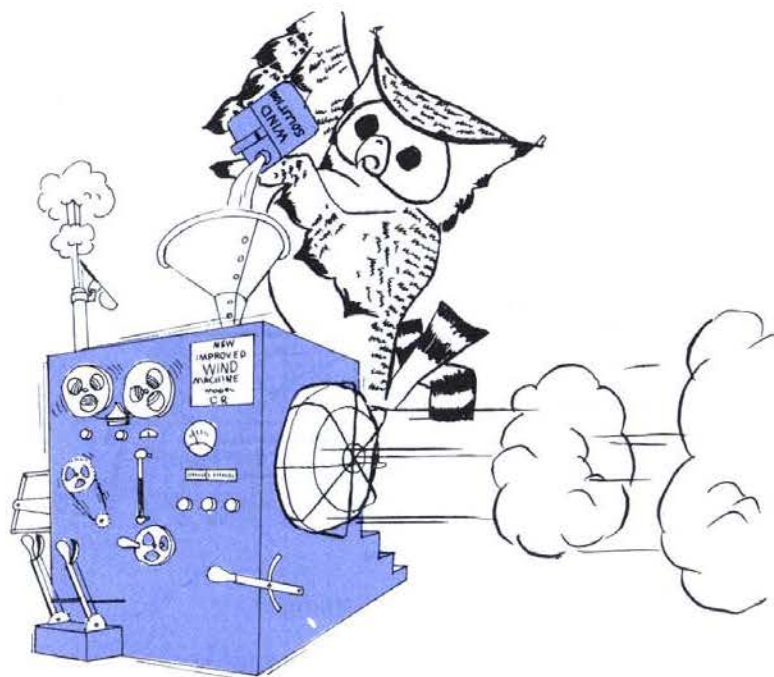

Fig. 23

NOTE: To subtract 29 from 84, locate 29 on scale to the left of TC index, and above 29 read 55.



WIND SOLUTION ON THE CR

“The ‘wind’ side of the CR IS a different looking gismo, but this is nothing to be shook-up about. Once we’ve breezed through an illustration, I’m sure you’ll agree that it’s as simple a solution as you’ve ever used.

“First of all let’s settle this business of ‘Magnetic vs. True’. Winds are always given (except by airport towers) in *True* and you can’t mix magnetic and true any more than you can oil and oxygen. The CR Computer gets you over this hump beautifully, by providing a *Magnetic-True conversion scale* on either side of the True Course Index **TC** (see Fig. 24). Just set the magnetic course on the green scale opposite the applicable variation and your true course is automatically lined up opposite the true course index.”

Example

Given: Magnetic course.....284°
 Variation.....14°E
Find: True Course

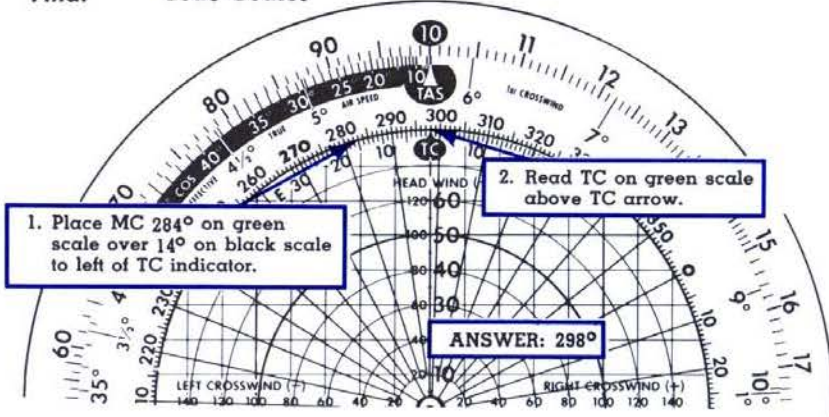

Fig. 24

“Remember the good old wind triangle?”

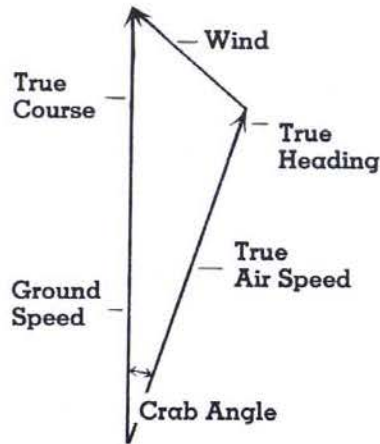

Fig. 25

“It’s a time-honored institution but it takes both time and space. You can’t put a wind triangle in your pocket, but the CR solves the triangle trigonometrically and you *can* put the CR in your pocket.

“In the wind triangle above, if you draw a line from the end of the TH-TAS line perpendicular to the TC-GS line, you will have a small triangle at the top of the original triangle.

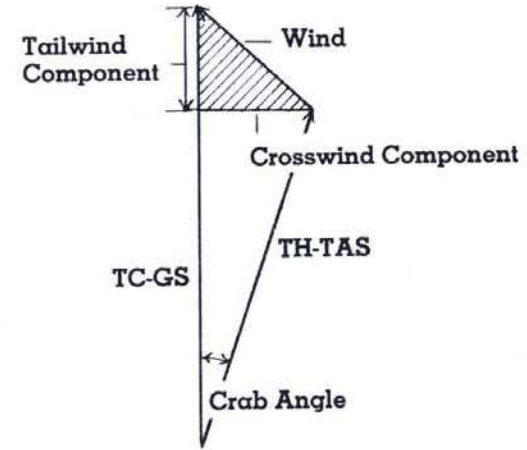

Fig. 26

“This is the triangle that fits on the CR Computer.”

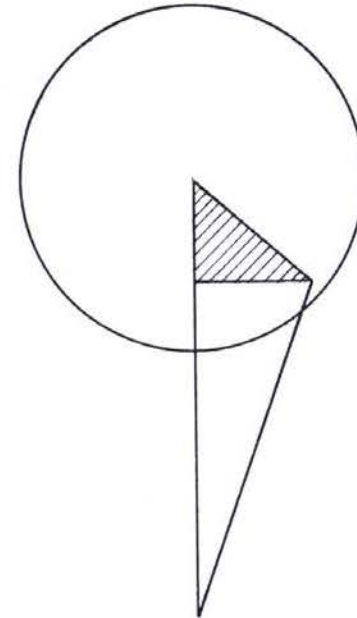

Fig. 27

“This diagram assumes that you can add the tailwind component to the true air speed to get ground speed, and for small crab angles this is very close to true, any inaccuracy being too small

to bother about. However, for crab angles of 10° or more the CR Computer handles the matter with a simple additional step that gives additional accuracy. The step will be explained later in a sample problem."

"Instead of drawing arrows on your computer, all that is necessary is to place a dot at the spot that indicates the end of the wind arrow. Make the dot small for accuracy; then draw a circle around it so you can find it again when you look for it."

NOTE: Two wind scales on the horizontal and vertical lines radiating from the center of the computer make the CR especially flexible for different types of aircraft. Use the large scale (from 0 to 80) if the wind is less than 80 knots or MPH. Use the small scale (from 0 to 160) if the wind is more than 80. Once you have chosen the desired scale, use it throughout the problem, taking care not to mix the two scales within the same problem.

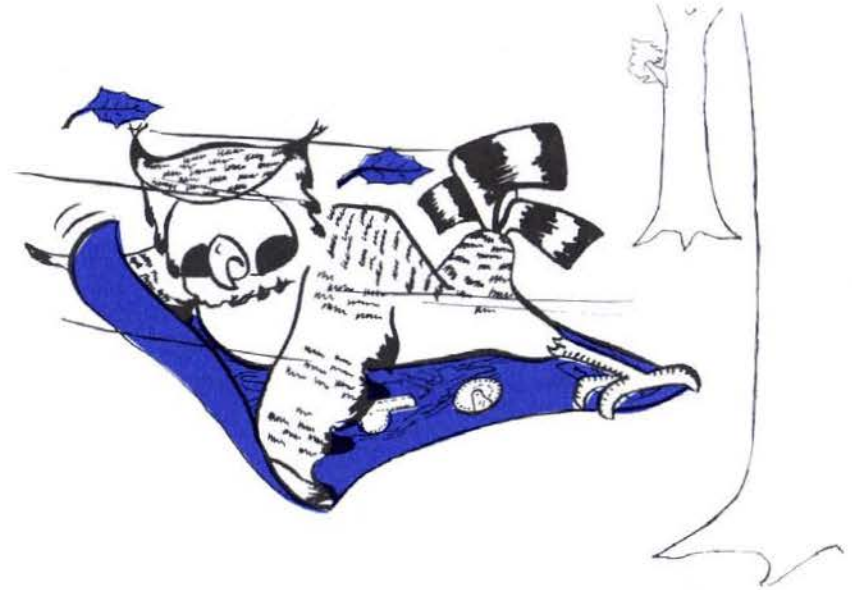

FLIGHT PLANNING WITH FORECAST WINDS

"Let's tackle this wind thing first from a 'Flight Planning' standpoint. Our proposed flight will be made in two legs so that we can demonstrate certain advantages of your CR Computer. Either knots or MPH can be used in a wind problem, provided the chosen unit of measure is used consistently throughout the problem."

Leg No. 1

Given: True Air Speed.....180 MPH
Magnetic Course.....140°
Variation.....10°W
Wind.....10 MPH from 100° True

Find: Crab angle, magnetic heading and ground speed.

Solution: (See Fig. 28)

1. Set the true air speed index  on 18 (180 MPH).

- Find the magnetic course, 140° , on the green scale and rotate this scale until the 140° is just above the 10° westerly variations mark. Your true course, 130° , is now just above the \uparrow TC index.
- Now locate your wind dot by first finding the wind direction, 100° , on the green scale and where the 100° "radial" intersects the 40 knot "circle", place your pencil dot.
- Reading directly down from the pencil dot, we see that we have a left crosswind component of 20 MPH. Now switch to the computer's outer scale and opposite 20 MPH (20), find the crab angle of 6° plus.
- The pencil dot shows that we have a left crosswind, therefore a left crab, so we subtract crab angle from magnetic course to obtain magnetic heading. $140^\circ - 6^\circ = 134^\circ$ our Magnetic Heading.
- Returning to the pencil dot, and reading directly to the right of it, we see that we have a headwind of 35 MPH. Subtract headwind from true air speed and you have ground speed. $180 \text{ MPH} - 35 \text{ MPH} = 145 \text{ MPH}$, our Ground Speed.

Answer: 6° left crab, 134° magnetic heading, 145 MPH ground speed.

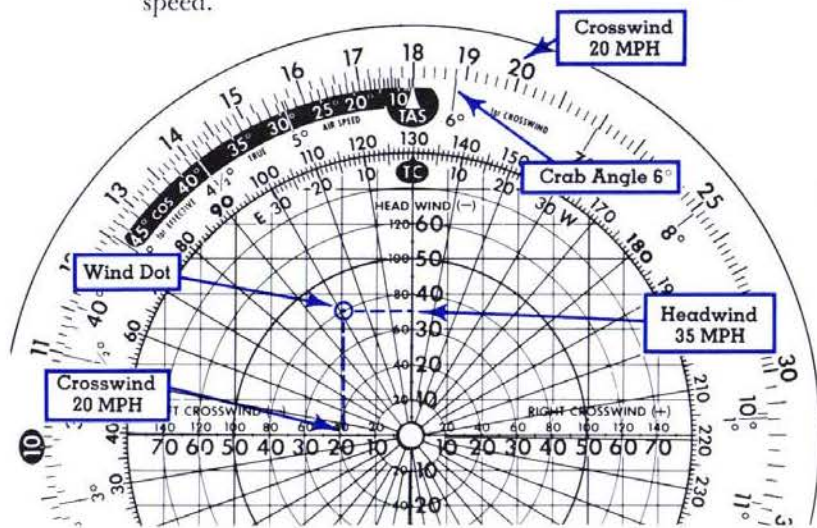

Fig. 28

Leg No. 2

Given: True Air Speed.....180 MPH
 Magnetic Course.....186°
 Variation.....11°W
 Wind.....40 MPH from 100° True

Find: Crab Angle, Magnetic Heading and Ground Speed

Solution: (See Fig. 29)

- Keep the true air speed index on 180 MPH and merely rotate the green scale to line up the new course, 186° magnetic, with the variation, 11° westerly. IMPORTANT! From the SAME pencil dot, you are now ready to read your next crab angle and headwind or tailwind – simple, isn't it?
- Reading down from the pencil dot, we determine a left crosswind (component) of 39 MPH and from the outer scale (at 39), a crab angle of 12° plus.
- Magnetic course minus left crab, $186^\circ - 12^\circ = 174^\circ$, our Magnetic Heading.
- Reading right from the pencil dot, we determine a headwind (component) of 10 MPH. Now, we could just subtract this from our true air speed as we did on our FIRST COURSE and come up with an approximate ground speed of 170 MPH – but if the crab angle exceeds 10° , always take the following additional step.
- Find the short, black 'effective true air speed' scale just to the left of the \uparrow TAS index. Locate on this scale your crab angle of 12° and read directly above your effective true air speed of 176 MPH. This is the figure from which you should subtract the headwind of 10 MPH, to get an accurate Ground Speed of 166 MPH.

Answer: 12° left crab, 174° magnetic heading, 166 MPH ground speed.

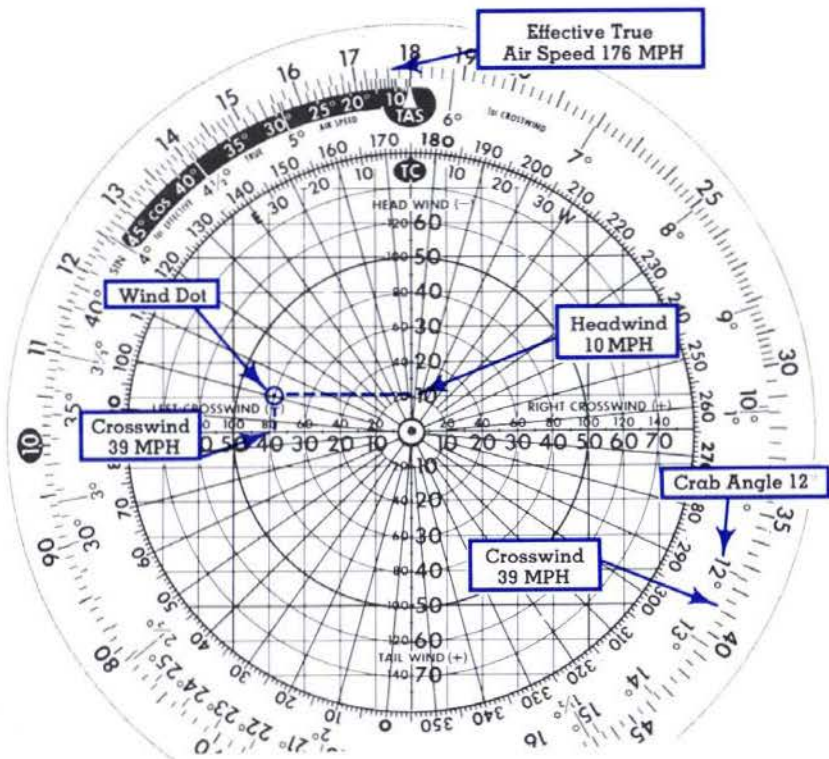

Fig. 29

NOTE: Be sure to use Effective True Air Speed opposite black section to left of TAS arrow for all problems involving a crab angle of 10° or greater. In this case, headwind or tailwind must be applied to Effective True Air Speed rather than to True Air Speed.

Problems 13

Find crab angle, magnetic heading, ground speed.

	True Air Speed	Magnetic Course	Variation	Wind Velocity	Wind (True) Direction
1.	310 kts.	254°	6°E	30 kts.	240°
2.	165 kts.	130°	5°W	20 kts.	270°
3.	130 MPH	350°	11°E	30 MPH	290°



FINDING WINDS IN FLIGHT

“Quite often, after you get upstairs, you find the wind is not behaving as the weather-guesser said it would. You must hold a different heading from that originally estimated, in order to make good your course, and you are crossing check points ahead of or behind planned times. You know how fast and where you’re going (ground speed and true course) . . . also the heading that’s getting you there (true heading) . . . but without accurate wind information you can’t re-estimate the legs ahead. Hence you need to determine the *actual* wind direction and velocity.”

Let’s assume the following:

Given: True air speed 180 MPH
 True course 175°
 True heading 160°
 Ground speed 144 MPH

Find: Actual wind direction and velocity

Solution: (See Fig. 30)

1. Set the \blacktriangle index on 180 MPH.
2. Set 175° at the true course index.
3. Subtract the true heading from the true course to get the crab angle. $175^\circ - 160^\circ = 15^\circ$ crab. Since the true heading is less than the true course we know it must be 15° left crab and hence the wind is from the left.
4. Crab angle is fairly high so we should determine and use "effective" true air speed. Find 15° on the short black scale and read directly above... 174 MPH, our *effective true air speed*.
5. Determine the difference between *effective true air speed* and actual ground speed. This will be the headwind or tailwind component which you will spot on your computer. In this example, $174 \text{ MPH (ETAS)} - 144 \text{ MPH (G.S.)} = 30 \text{ MPH headwind}$. From the 30 MPH headwind figure, draw a line to the left. (Left crab... wind from the left.)
6. Now find the crosswind component. Read middle disk (crosswind scale) to 15° , and above find 47 MPH crosswind component. From the horizontal 'crosswind' line, at the 47 MPH position, draw a line upward.
7. Find the point of intersection of the two lines you have just drawn. This is your wind dot. Its position shows that we have an *actual wind from 118° true at 55 MPH*.

Answer: Wind from 118° at 55 MPH.

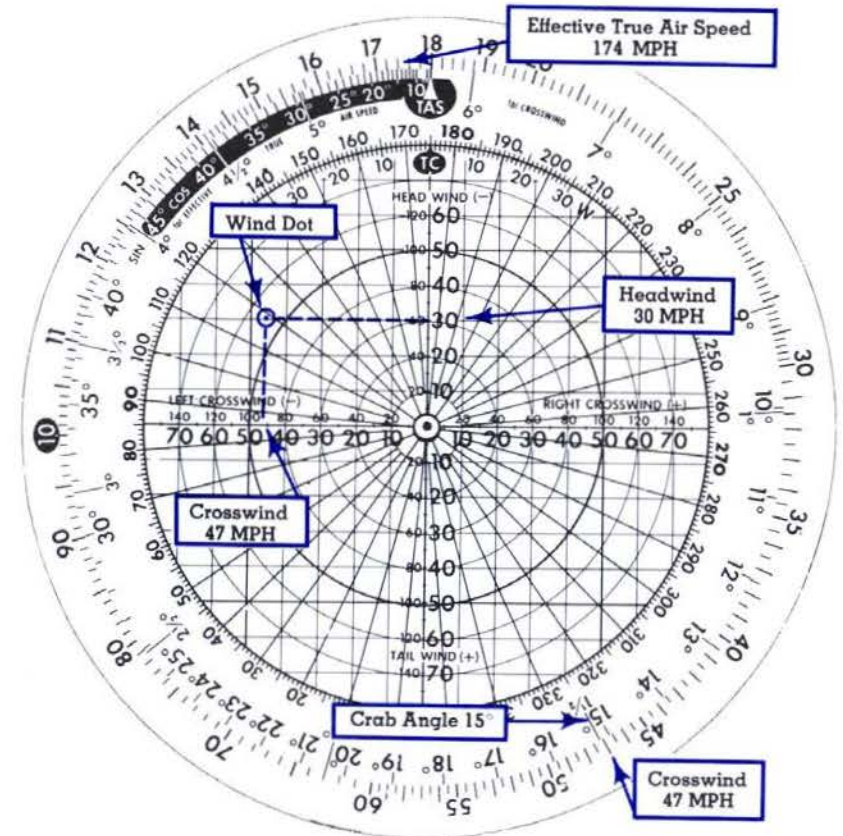

Fig. 30

Problems 14

Find wind direction and velocity.

	True Course	True Heading	True Air Speed	Ground Speed
1.	106°	102°	240 MPH	220 MPH
2.	320°	309°	130 kts.	142 kts.
3.	164°	175°	210 MPH	222 MPH



TRUE COURSE (TRACK) AND GROUND SPEED

“Sometimes it’s mighty interesting to know where you’re going and how fast. Your air speed and heading are usually available in flight. If, in addition, you have some wind information (either reported or forecast) you can easily find true course and ground speed.”

Given: True air speed 156 MPH
 Magnetic heading 289°
 Variation 7°W
 Wind 40 MPH from 180° True

Find: True course and ground speed.

Solution: (See Figures 31 and 32)

1. Set the \blacktriangle index on 156 MPH.
TAS
2. Find the magnetic heading, 289°, on the green scale and set it opposite the variation, 7°W. You now have the true heading (282°) rather than true course under the \bullet index. This setting is only a temporary one to give an approximate crab angle

to use in determining the actual true course. The top disc will be moved again so that the true course is under the \bullet index.

3. Locate the wind dot by finding the 180° line on the green scale and marking the point where this line intersects the green 40 MPH circle.
4. Reading directly up from the wind dot we see that there is a left crosswind component of 39 MPH. Looking at the outer scale, find 39 and opposite it read 14° crab angle.

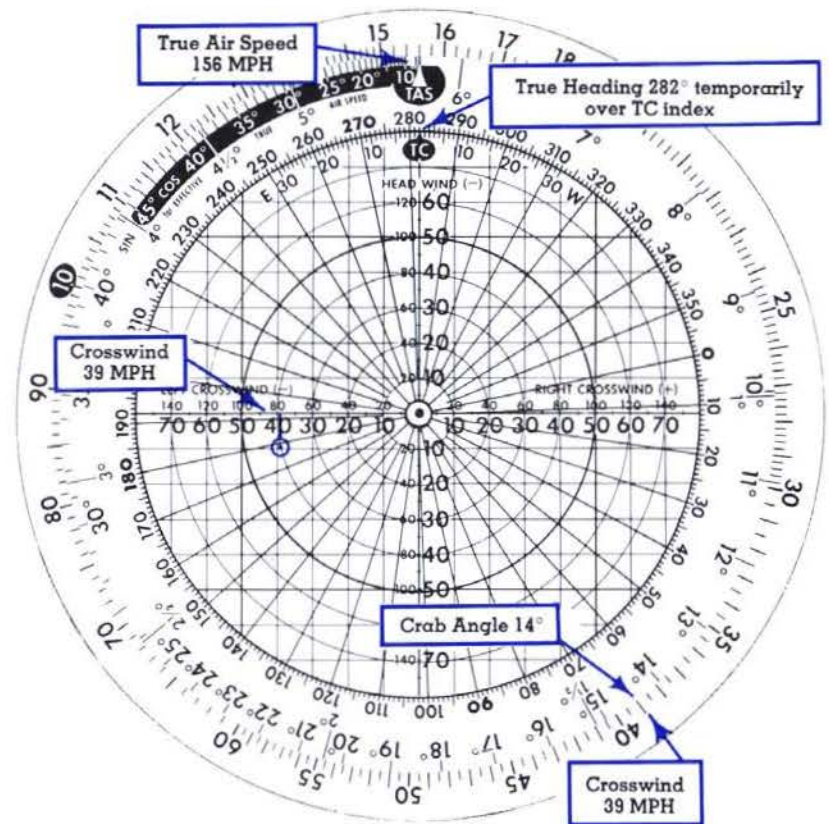

Fig. 31

5. Since the wind is from the left, the true heading must be left of the true course. Therefore rotate the top disc 14° to the left (counter clockwise) until the 282° true heading is over 14 on the black scale. Now the \bullet index points to 296°.

6. Looking directly above the wind dot after the above move, you now find that the crosswind component has changed to 36 MPH instead of 39 MPH. Locate 36 on the outer scale and find opposite it a crab angle of 13° . It now appears that the first crab angle of 14° was 1° too much. Therefore, back off 1° of the adjustment made in step 5, making a true course reading of 295° . A glance at the crosswind component shows that the crosswind is still 36; so this is the final computer adjustment for the problem, and the true course is 295° .
7. If the crab angle had been less than 10° you would add the tailwind component directly to the true air speed. However, since the crab angle in this problem is greater than 10° , it is necessary to use *effective true air speed* in finding ground speed. Find 13° on the short black scale to the left of the \blacktriangle TAS index, and directly above read the effective true air speed, 152 MPH.
8. Looking again at the wind dot, note directly to the right of it on the vertical scale that there is a 17 MPH tailwind component. Add this to the effective true air speed to give ground speed. $152 \text{ MPH} + 17 \text{ MPH} = 169 \text{ MPH}$ ground speed.

Answer: True course..... 295°
 Ground speed.....169 MPH

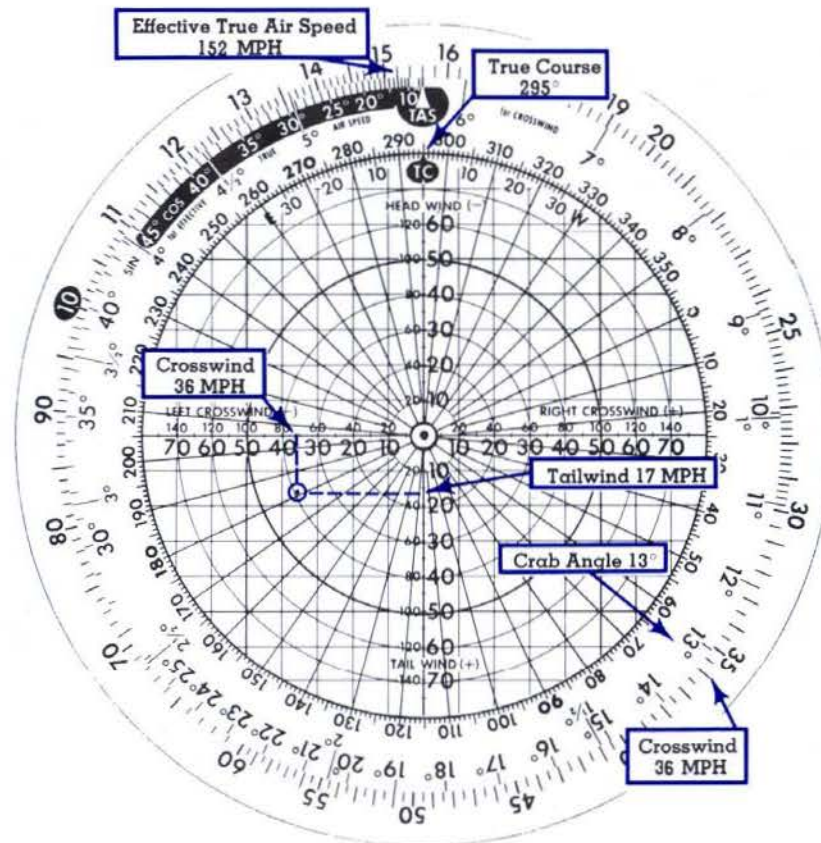
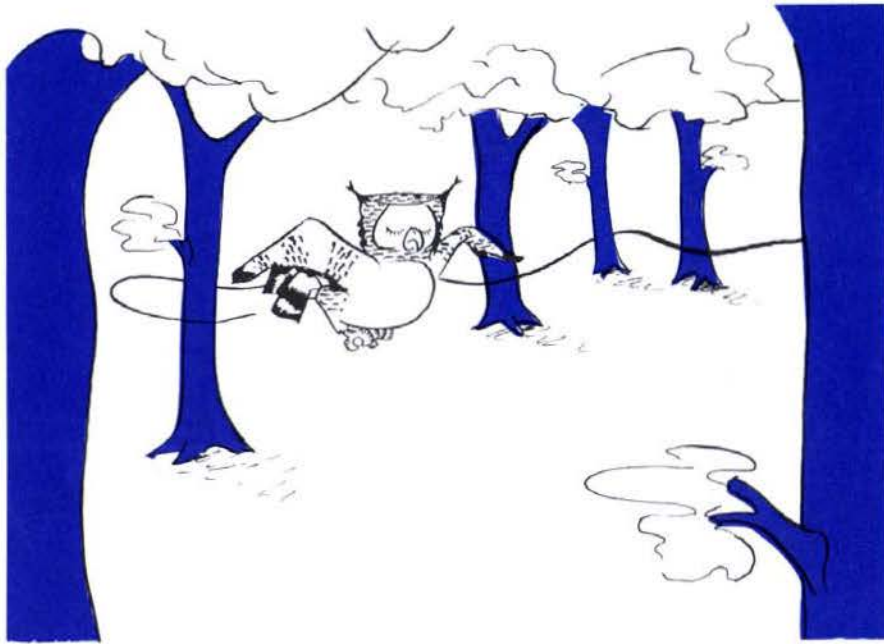

Fig. 32

Problems 15

Find true course and ground speed.

	True Air Speed	True Heading	Wind Velocity	Wind (True) Direction
1.	220 MPH	62°	20 MPH	280°
2.	133 kts.	86°	35 kts.	40°
3.	550 kts.	315°	80 kts.	0°



TRUE HEADING AND TRUE AIR SPEED

“Have an appointment to keep? Whether it’s an important meeting, an airplane to intercept, or a flight schedule to make good, there are times when you want to know the true air speed that will enable you to make good a given ground speed. Here’s how:”

Given: True course 56°
 Desired ground speed . . . 166 kts.
 Wind 45 kts. from 120° True

Find: True air speed and true heading.

Solution: (See Fig. 33)

1. Move top disc until TC index points to 56° .
2. Locate wind dot by finding 120° on green scale and placing a dot on the 120° line half way between the 40 and 50-knot circles.
3. Directly to the left of the wind dot read 20 knots on the vertical headwind scale.

4. Since the desired ground speed is 166 knots and there is a 20-knot headwind component, you know that the true air speed (or effective true air speed if the crab angle is 10° or greater) must be $166 + 20$, or 186 knots. Place the $\blacktriangle_{\text{TAS}}$ index on 186.
5. Directly below the wind dot read 40 knots on the horizontal right crosswind scale. Locate 40 on the outer scale of the computer and note that it is close to 12° crab angle on the inner scale.
6. Since the crab angle is greater than 10° , the figure 186 in step 4 above must be *effective true air speed* rather than true air speed. Locate 12° on the black scale to the left of the index and move the bottom disc till 186 is opposite 12° on the black scale. Check to see that the 40-knot crosswind component on the outer scale is still close to 12° on the inner scale. If the angle opposite 40 had been changed by the preceding computer movement it would have been necessary to make a second adjustment to line up the effective true air speed with the proper crab angle on the black scale. Since 40 is still close to 12° in this problem, no further disc movement is necessary. Note that the $\blacktriangle_{\text{TAS}}$ index points to 19 (190 knots).
7. Since the wind is from the right, add the 12° crab angle to the true course to get true heading. To do this easily, locate 12° on the black scale to the *right* of the TC index and above it read 68° , the true heading.

Answer: True air speed.....190 knots
 True heading..... 68°

NOTE: If the crab angle had been less than 10° , step 6 would have been unnecessary, as the headwind component would have been added to the desired ground speed to give the true air speed directly.

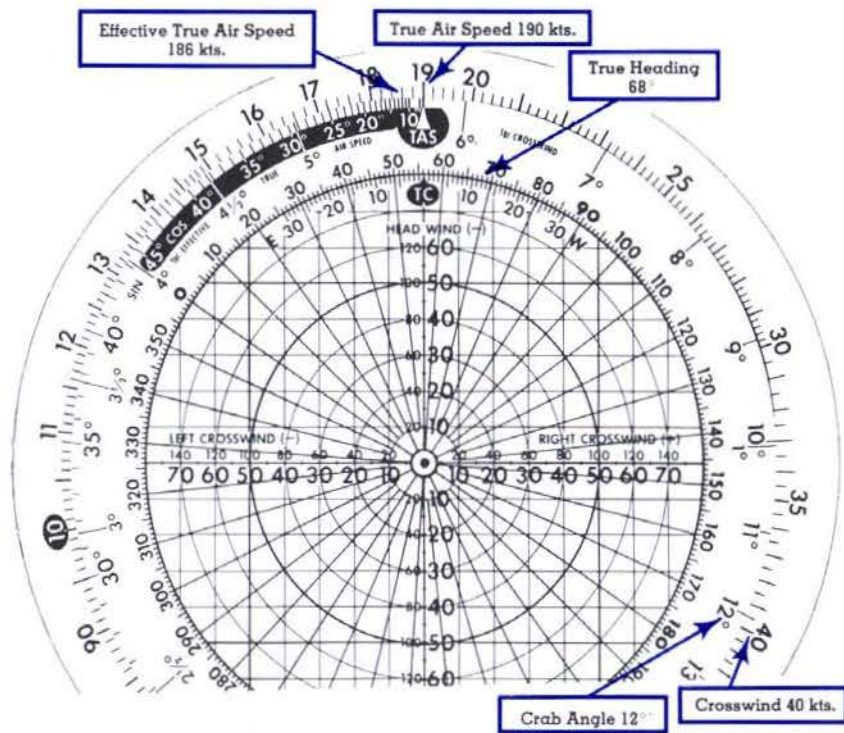
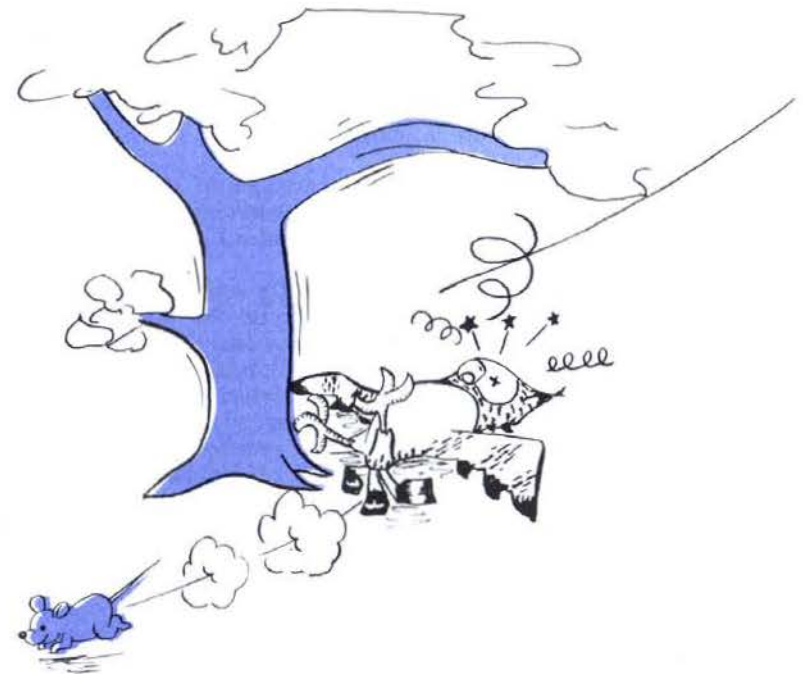

Fig. 33

Problems 16

Find true heading and true air speed.

	True Course	Ground Speed	Wind Velocity	Wind (True) Direction
1.	58°	220 kts.	30 kts.	280°
2.	323°	570 kts.	95 kts.	80°
3.	60°	170 MPH	40 MPH	310°



OFF-COURSE CORRECTION

“Unless you have the instinct of a homing pigeon, some day you’ll find yourself off course. This need not be distressing if you continue on your original heading until you reach a recognizable check point. Measure your distance off course, miles flown and miles to destination. Then two easy computer adjustments will give you the number of degrees to correct your heading to take the shortest route to your destination.”

Given: Miles flown..... 40
 Miles off course..... 5
 Miles to destination.....160

Find: Degrees correction to heading to reach destination directly.

Solution: (See Fig. 34)

1. On wind side of computer place \blacktriangle index opposite 40 (miles flown).

- Locate 5 miles (50) on the outer scale and opposite it read 7° . This is the number of degrees you must correct your heading in order to parallel your intended course.
- It is now necessary to find the number of degrees additional correction needed to reach your destination. Place the index opposite 16 (160 miles to destination).
- Again locate 5 miles (50) on the outer scale. Note that 5 miles (50) is approximately opposite 18° on the inner scale. However, it is also opposite a point between $1\frac{1}{2}^{\circ}$ and 2° on another scale directly inside the one containing the 18° . Thus you must decide whether the next correction should be 18° or 2° . Common sense will tell you that 2° is the logical correction. However, if you are in doubt, remember the rule that 1° of drift will give approximately 1 mile off course in 60.
- Add the degrees correction necessary to parallel your course and the additional correction necessary to reach destination, to get the total correction needed. $7^{\circ} + 2^{\circ} = 9^{\circ}$.

Answer: 9°

NOTE: If you are off course to the right, it will be necessary to correct to the left, so subtract the degrees correction from your compass heading. If you are off course to the left, correct to the right by adding the correction to your compass heading.

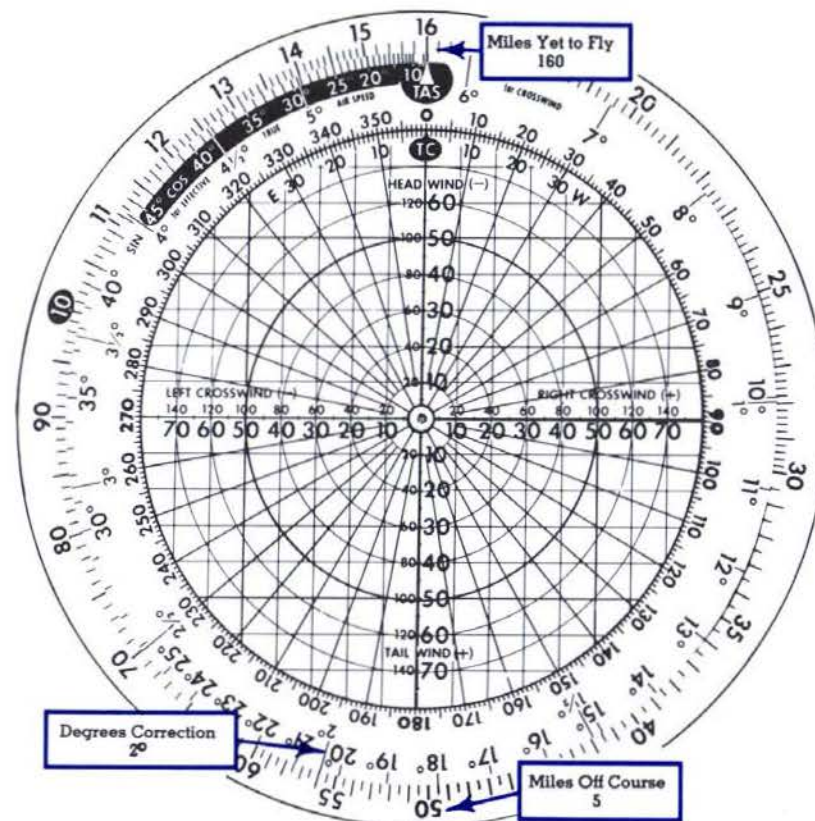

Fig. 34

Problems 17

Find degrees correction necessary to reach destination.

	Miles Flown	Miles Off Course	Miles to Destination
1.	82	10	140
2.	14	2	115
3.	56	11	100

RADIUS OF ACTION

Radius of action of an aircraft is the greatest distance that it can fly along a certain course under known conditions of air speed, wind and fuel consumption and return to the starting point with desired fuel reserve. The "time to turn" in a radius of action problem is the maximum

elapsed time that the aircraft can fly outbound along the assigned track.

If the wind, true course, and true air speed are known, it is possible to work two separate wind problems on the computer to obtain G.S. out and G.S. back. However, since the relation of the wind to the flight track on the inbound flight will be 180° different from its relation to the outbound flight, you can solve for both ground speed out and ground speed back in one problem. (See Fig. 35.)

True air speed 285 kts.
 Wind 30 kts. from 35°
 Fuel available 3½ hrs.
 True course outbound 340°

In this problem the second wind dot has been placed on the computer to demonstrate the fact that if headwind or tailwind component is known for a given course, the component will be the same velocity for a reciprocal course but will be from the opposite direction. Thus, an 18 kt. headwind for G.S. out becomes an 18 kt. tailwind for G.S. back; and a tailwind for G.S. out would become the same velocity headwind for G.S. back. Referring to figure 35, note also that the crab angle will be the same for the course out and the course back, but it will be applied on opposite sides. A right crab angle on the outbound course becomes the same size left crab angle on the inbound course.

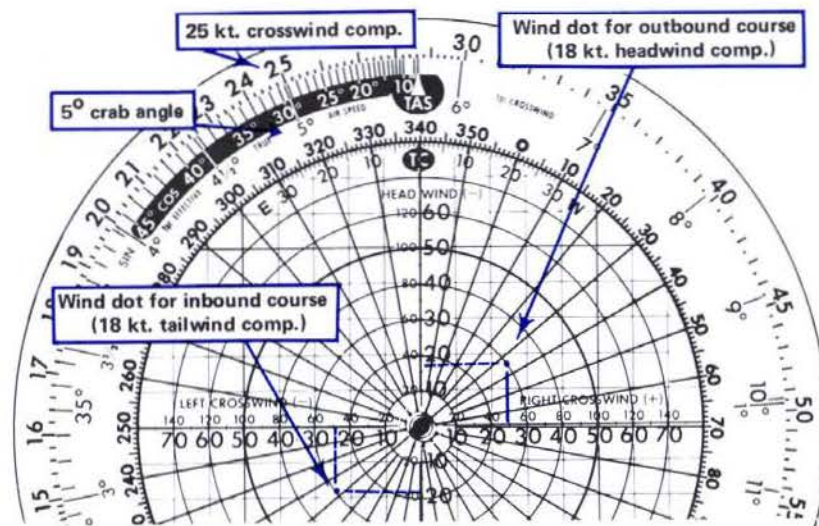

Fig. 35

1. Subtract the 18 kt. headwind component from the TAS to get G.S. out. (285 - 18 = 267)
2. Add the 18 kt. tailwind component to the TAS to get G.S. back. (285 + 18 = 303)
3. Add G.S. out to G.S. back (267 + 303 = 570)
4. Place 570 on the outside scale over 3:30 (fuel available) on the inside scale. (See Fig. 36.)
5. Then, locate 303 (G.S. back) on the outside scale and opposite it read the time to turn, 1:52.

Answer: Time to turn = 1:52 after departure

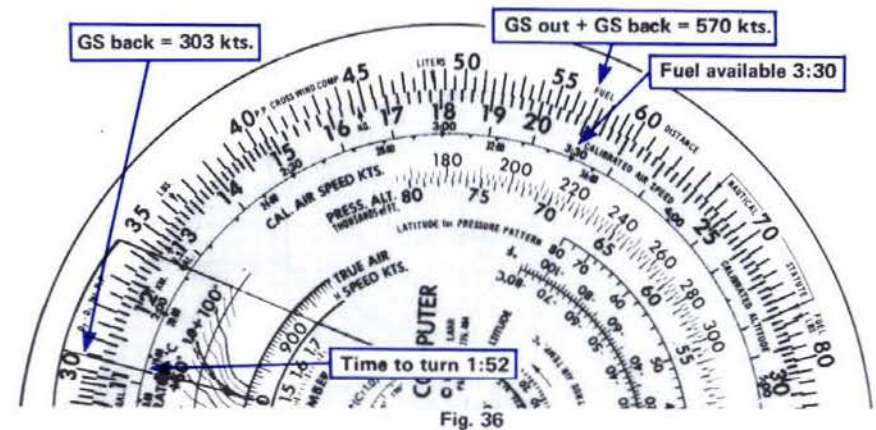

Fig. 36

WIND COMPONENTS FOR TAKEOFF AND LANDING

Some pilot's operating handbooks include a demonstrated crosswind component. This indicates the maximum crosswind component that was demonstrated for takeoff and landing during aircraft certification testing. Normally, wind acting on an aircraft during takeoff or landing is at some angle between the aircraft's flight path (ground track) and 90° to the ground track. The headwind component is acting 180° to the flight path and the crosswind component is acting 90° to the flight path. Under these circumstances, both the headwind and the crosswind components are somewhat less than the total wind velocity.

For example, if the active runway is 29 (290° magnetic), and the tower has reported a wind of 330° (winds reported by a tower also are magnetic) at 30 kts, the crosswind and headwind components are determined as follows:

1. Set runway heading over the true course (TC) as shown in figure 37.
2. Locate direction of wind.
3. Proceed inbound along wind line until intersecting the wind velocity, then make a dot.
4. Proceed vertically downward from the dot and read 19 kts. of crosswind on the crosswind line.
5. Moving horizontally from the dot, read the headwind component of 23 kts. on the headwind line.

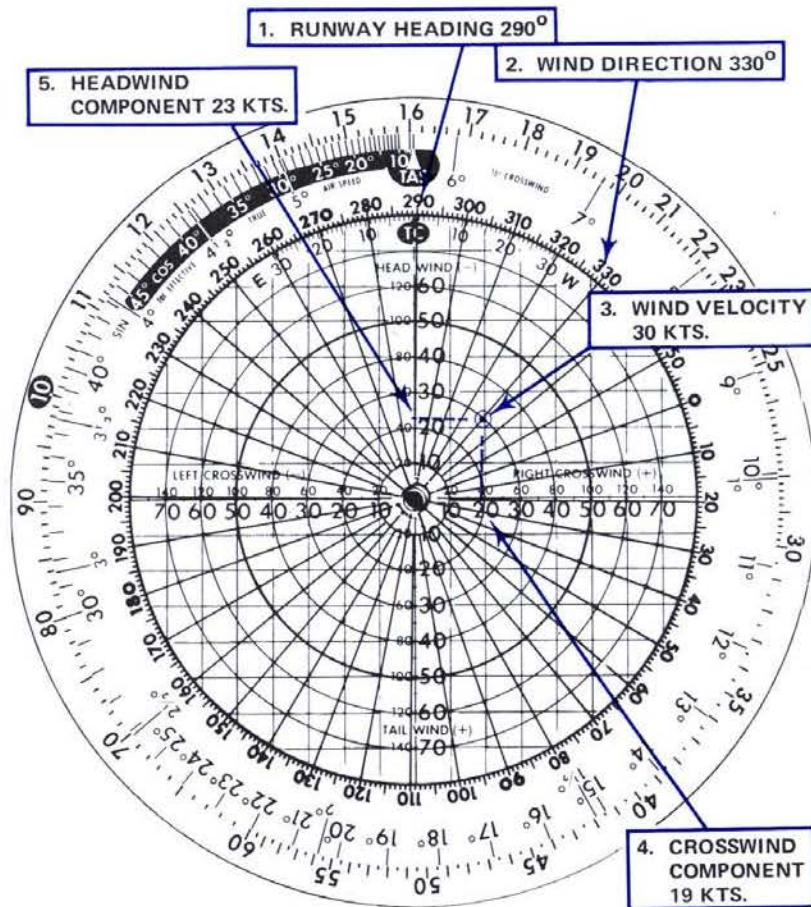

Fig. 37

Part C

ANSWERS, DEFINITIONS AND HINTS

ANSWERS TO PRACTICE PROBLEMS

PROBLEMS 1

- | | | |
|------------------|------------------|------------|
| 1. 256 naut. mi. | 3. 1:30 | 5. 267 kts |
| 2. 194 MPH | 4. 270 stat. mi. | 6. 3:44 |

PROBLEMS 2

- | | | |
|------------------|-----------------|--------------|
| 1. 115 stat. mi. | 5. 44 imp. gal. | 9. 53 kg. |
| 2. 170 naut. mi. | 6. 96 U.S. gal. | 10. 198 lbs. |
| 3. 145 km | 7. 900 liters | 11. -4°F |
| 4. 135 naut. mi. | 8. 37 U.S. gal. | 12. 10°C |

PROBLEMS 3

- | | | | |
|----------------|----------------|---------------|-------------|
| 1. 70 meters | 3. 25 meters | 1. 210 lbs. | 3. 450 lbs. |
| 2. 11,480 feet | 4. 18,040 feet | 2. 3,603 lbs. | 4. 135 lbs. |

PROBLEMS 5

- | | | | |
|---------------|---------------|----------------|----------------|
| 1. 4,100 feet | 3. 6,890 feet | 1. 12,200 feet | 3. 7,580 feet |
| 2. 2,820 feet | | 2. 5,890 feet | 4. 21,810 feet |

PROBLEMS 7

- | | | |
|------------|-------------|-------------|
| 1. 188 MPH | 2. 339 kts. | 3. 470 kts. |
|------------|-------------|-------------|

PROBLEMS 8

1. 5° temp. rise, -5°C true temp.
2. 24° temp. rise, -34°C true temp.

PROBLEMS 10

1. 23 kts. from right
2. 35 kts. from right
3. 18 kts. from right

PROBLEMS 11

1. 391
2. 1.71
3. 1.8

PROBLEMS 12

1. 27 min.
2. 54.5 stat. mi.

PROBLEMS 13

Crab Angle	Magnetic Heading	Ground Speed
1. 2° Left	252°	282 kts.
2. 4° Right	134°	181 kts.
3. 13° Left	337°	117 MPH

PROBLEMS 14

1. 65°, 26 MPH
2. 200°, 29 kts.
3. 276°, 43 MPH

PROBLEMS 16

1. TH 52°, TAS 199 kts.
2. TH 332°, TAS 534 kts.
3. TH 46°, TAS 161 MPH

PROBLEMS 15

1. TC 65°, GS 236 MPH
1. TC 99°, GS 112 kts.
1. TC 309°, GS 496 kts.

PROBLEMS 17

1. 11°
2. 9°
3. 17°

DEFINITIONS

Definitions in this section conform to common usage in the United States. Some differences will be apparent to pilots accustomed to certain ICAO definitions. For instance, *course* is normally used in the U.S. instead of *track*; and *inches of mercury (in. Hg)* are used instead of *millibars* or *hectopascals*.

Course (C)—Intended direction of flight in a horizontal plane measured in degrees from north.

Track (T)—Actual flight path of an aircraft over the surface of the earth, usually expressed in degrees from north.

Heading (H)—Direction in which the longitudinal axis of the aircraft is pointed with respect to north. True heading is related to true north. Magnetic heading is related to magnetic north and is true heading corrected for magnetic variation. Compass heading is magnetic heading corrected for compass deviation.

Crab Angle (CA)—The angle (relative to the true course) at which an aircraft must be headed into the wind in order to make good the desired course. Also called wind correction angle (WCA).

Drift Angle (DA)—The angular difference between the course and the track as the result of wind effects, when the aircraft heading is the same as the course. Note: For a given course, wind, and air speed, the crab angle is not exactly equal to the drift angle because heading of the aircraft relative to the direction of the wind is different in the two cases.

Indicated Air Speed (IAS)—The speed of the airplane as observed on a standard air speed indicator. It is the air speed without correction for indicator, position (or installation), or compressibility errors.

Calibrated Air Speed (CAS)—The air speed indicator reading corrected for position (or installation) and instrument errors. (CAS is equal to TAS at sea level in standard atmosphere.) The color coding for various design speeds marked on air speed indicators may be IAS or CAS.

Equivalent Air Speed (EAS)—The air speed indicator reading corrected for position (or installation), or instrument error, and for adiabatic compressible flow for the particular altitude. (EAS is equal to CAS at sea level in standard atmosphere.)

True Air Speed (TAS)—The air speed of an aircraft relative to undisturbed air. It is equivalent air speed corrected for air-density variation from the standard value at sea level. True air speed increases with altitude when indicated air speed remains the same.

Effective True Air Speed (Eff. TAS)—The amount of true air speed to which the headwind or tailwind component is applied to give ground speed. At small crab or drift angles, the effective true air speed is so close to the true air speed that they may be considered the same. At crab or drift angles of 10° or greater, effective true air speed will be less than true air speed.

Ground Speed—The rate of motion over the ground. The result of interaction between true air speed and wind speed in their relative directions of motion.

Indicated Altitude (IA)—Altitude read on a standard altimeter, assuming the altimeter is correctly adjusted to show the approximate height of the aircraft above mean sea level (MSL).

Calibrated Altitude (CA)—Indicated altitude corrected for mechanical errors resulting from complexity of installation.

Pressure Altitude (PA)—Altitude read on a standard altimeter when the instrument is adjusted to indicate the height above the Standard Datum Plane (29.92 inches of mercury, 1013.25 millibars or 1013.25 hectopascals.)

Density Altitude (DA)—Pressure altitude corrected for nonstandard temperature. Basically, air density, as applied to flight, is the measure of the number of molecules of air per cubic inch which can act upon the aircraft surfaces with the resulting forces of lift, drag, etc. Density of a gas is determined by pressure and temperature. Density altitude is the theoretical density of a standard atmosphere at that altitude. Aircraft performance is directly related to air density; therefore, performance is determined by density altitude regardless of indicated or actual altitude.

True Altitude (TA)—The true height above sea level. This is usually a mathematical value determined by computer and, based upon standard or uniform temperature and pressure lapse rates assumed in the computer solution. Therefore, the computer solution provides only an approximate true altitude. If the temperature between the surface and the aircraft does not decrease at the standard rate of 2°C per 1,000 feet, or if the rate of decrease in pressure is nonstandard, reliance on a computer solution to determine obstruction clearance can be hazardous.

Mach—Related to the speed of sound. Mach 1.0 is the speed of sound in the atmosphere. All factors other than temperature have practically no effect on the speed of sound, but temperature has a large effect. Mach 1 is 620 knots at -20°C and 690 knots at +40°C. Therefore, a specific Mach number does not determine speed in MPH or knots directly, but a specific Mach number has a specific MPH or knots equivalent which is *different* for each *different* temperature.

Temperature Rise—Increase in temperature indication over true outside air temperature resulting from the heat of friction and the heat of compressibility of the air.

Standard Atmosphere—Pressure and temperature values for any given altitude, arbitrarily established as a standard basis to which all problems related to altitude may be compared. The set of standard conditions presently used in the U.S. is known as the *International Standard Atmosphere (ISA)*. It has been adopted by most of the nations and airlines of the world. The ISA actually represents the mean or average properties of the atmosphere; that is, it represents the year-round average of the pressure-height temperature soundings observed over a period of years. The standard values include sea level pressure of 29.92" Hg and a temperature of 15°C (59°F); the standard lapse rates (decrease) are approximately 1" Hg per 1,000 feet increase in altitude and 2°C (3.5°F) per 1,000 feet increase (up to the tropopause).

SOME HINTS ON THE CR

by E. B. Jeppesen

In my wide experience, both in private and airline flying, I have never encountered another computer which could solve so many common everyday flying problems so simply and quickly as the CR. The following is a list of a few of the easy methods and alternate approaches for solving common problems. Space is provided for noting hints of your own.

I would be pleased to hear about any new ideas or methods that you develop with your computer so that they can be passed on to other users of the CR.

E. B. JEPPESEN

HINT—It's easy to determine the effect of possible wind shifts, crab or ground speed. In flight planning, when you're figuring your load and fuel rather close, a shift in the wind could make a big difference. Just spot the wind dot from reported wind, then rotate the green disk say 20° or 30° either side of true course and by reference to the black grid you can quickly tell how serious, in terms of crab and ground speed, a wind shift will be.

HINT—You never need to use the short black scale (wind side) except for effective TAS, and then only with excessive crab angle, so don't let the fact that it's based on trigonometry scare you.

HINT—For winds less than 10 MPH (or knots) let the black grid represent units of 1 instead of units of 10 to get the wind dot away from the center for easier reading.

HINT—Another approach will give TAS using the modern method from reported temperature without the necessity of "backing off" for temperature rise (not experienced in reported temperatures). Start with CAS over PA as in the modern method solution and note Mach number. Then set Mach index (in lower left small window) against reported temperature, and read against Mach number on outer scale of top disk TAS in knots on outer scale of base disk.

HINT—To check ground speed against section lines set miles on base disk against seconds on top disk and read MPH at sec. index (at 36 on top disk). Example, for 3 section lines in 43 seconds, set 3 on base against 43 on top and read 251 MPH at sec. index.

HINT—Some pilots are putting a mark at 313 on the top disk outer scale. This is used exactly the same as the sec. index above, but gives speed in knots from statute section lines.

HINT—If you have a permanent index mark you'd like to add, as for power setting for your particular aircraft, a hot needle just touched to the desired point will make a slight depression which will hold ink for a permanent mark.

HINT—A little vaseline wiped over the transparent wind disk not only makes it more transparent, it also makes it easier to wipe off pencil dots. Pencil will go on just as easy. It will not work for a pen, however.